

TM 10-3930-242-12

TECHNICAL MANUAL
OPERATOR AND ORGANIZATIONAL
MAINTENANCE MANUAL
FOR

TRUCK, LIFT, FORK, DIESEL ENGINE,
PNEUMATIC TIRED WHEELS,
ROUGH TERRAIN 6,000 LB. CAPACITY,
24 INCH LOAD CENTER
(ANTHONY MODEL MLT-6,
ARMY MODEL MHE-200)
NSN 3930-00-903-0900,
(CHRYSLER MODEL MLT-6CH,
ARMY MODEL MHE-202)
NSN 3930-00-937-0220,
(ATHEY MODEL ARTFT-6,
ARMY MODEL MHE-222)
NSN 3930-00-419-5744

This copy is a reprint which includes current
pages from Changes 1 through 3.

HEADQUARTERS, DEPARTMENT OF THE ARMY
JULY 1980

W A R N I N G

Death or severe injury may result if forklift truck engine is operated in an enclosed area without providing adequate ventilation. Exhaust fumes contain carbon monoxide, a colorless, odorless, poisonous gas.

W A R N I N G

Do not smoke or use open flame in vicinity where batteries are being charged. The charging process generates hydrogen, a highly explosive gas.

W A R N I N G

Do not remove radiator cap unless engine has stopped and cooled to reduce pressure.

W A R N I N G

Always be alert for personnel in the area during operation of the forklift truck.

W A R N I N G

Always bleed off the pressure before operating any part of the hydraulic brake system by operating the brake pedal several times with the engine not running. Failure to observe this warning may result in severe injury to personnel.

W A R N I N G

Operation of this equipment presents a noise hazard to personnel in the area. The noise level exceeds the allowable limits for unprotected personnel. Wear ear muffs or ear plugs.

W A R N I N G

Drycleaning solvent, P-D-680, used to clean parts, is potentially dangerous to personnel and property. Do not use near an open flame or excessive heat. The flash point of solvent is 138°F.

W A R N I N G

Compressed air used for cleaning purposes will not exceed 30 psi. Use only with effective chip guarding and personal protective equipment (goggles/shield, gloves, etc.)

CHANGE

HEADQUARTERS
DEPARTMENT OF THE ARMY
Washington D. C., 26 July 1991

No. 3

**OPERATOR AND ORGANIZATIONAL
MAINTENANCE MANUAL
(NSN 3930-00-327-1575)**

**TRUCK, LIFT, FORK; DIESEL ENGINE, PNEUMATIC TIRED WHEELS,
ROUGH TERRAIN, 6,000 LB CAPACITY, 24 INCH LOAD CENTER
ANTHONY MODEL MLT 6-2 ARMY MODEL MHE-230**

Current as of

TM 10-3930-242-12, 30 January 1987 is changed as follows:

1. *Inside Front Cover.* Add the following warning:

WARNING

If NBC exposure is suspected, all air filter media should be handled by personnel wearing protective equipment. Consult your unit NBC Officer or NBC NCO for appropriate handling or disposal instructions.

2. Remove old pages and insert new pages.
3. New or changed material is indicated by a vertical bar in the margin of the page.

Remove Pages

Pages 2-13

Pages 3-7

Pages 3-7.0 thru 3-7.3.

Page 3-9 thru 3-10

Page 4-4

Page 4-9 thru 4-14

Insert Pages

Pages 2-13

Page 3-7

Add pages 3-8 thru 3-8.3

Page 3-9 thru 3-10

Page 4-4

Page 4-9 thru 4-14

4. File this change sheet in front of the publication for reference purposes.

By Order of the Secretary of the Army:

GORDON R. SULLIVAN
General, United States Army
Chief of Staff

Official:

PATRICIA P. HICKERSON
Brigadier General, United States Army
The Adjutant General

Distribution:

To be distributed IAW DA Form 12-25-E (Block No. 2227) Operator and Unit maintenance requirements for TM 5-2410-223-24.

CHANGE

No. 2

HEADQUARTERS
DEPARTMENT OF THE ARMY
Washington, D.C., 18 July 1989

**OPERATOR AND ORGANIZATIONAL MAINTENANCE MANUAL
FOR
TRUCK, LIFT, FORK, DIESEL ENGINE, PNEUMATIC TIRED WHEELS,
ROUGH TERRAIN; 6,000 LB CAPACITY, 24 INCH LOAD CENTER
(ANTHONY MODEL MLT-6, ARMY MODEL MHE-200)
(NSN 3930-00-903-0900),
(CHRYSLER MODEL MLT-6CH, ARMY MODEL MHE-202)
(NSN 3930-00-937-0220),
(ATHEY MODEL ARTFT-6, ARMY MODEL MHE-222)
(NSN 3930-00-419-5744)**

TM 10-3930-242-12, 31 July 1980, is changed as follows:

1. Remove old pages and insert new pages as indicated below.
2. New or changed material is indicated by a vertical bar in the margin of the page and by a vertical bar adjacent to the illustration identification number.

Remove Pages

i and ii
1-1 and 1-2
2-5 through 2-10
3-5 through 3-8
3-11
4-1 through 4-4
4-41 and 4-42
A-1
C-1
D-9 and D-10

Insert Pages

i and ii
1-1 and 1-2
2-5 through 2-10
3-5 through 3-8
3-11/(3-12 blank)
4-1 through 4-4
4-41 and 4-42
A-1/(A-2 blank)
C-1/(C-2 blank)
D-9 and D-10

3. File this change sheet in front of the publication for reference purposes.

By Order of the Secretary of the Army:

Official:

CARL E. VUONO
General, United States Army
Chief of Staff

WILLIAM J. MEEHAN II
Brigadier General, United States Army
The Adjutant General

Distribution:

To be distributed in accordance with DA Form 12-25F, Operator and Unit maintenance requirements for Fork Lift, 6000 LB Capacity, Rough Terrain, Pneumatic Tire, Diesel (Model MHE-200, 202, 222) Cumulative.

CHANGE }
NO. 1 }

HEADQUARTERS
DEPARTMENT OF THE ARMY
Washington, D. C., 30 January 1987

**TECHNICAL MANUAL
OPERATOR AND ORGANIZATIONAL MAINTENANCE MANUAL
FOR
TRUCK, LIFT, FORK, DIESEL ENGINE, PNEUMATIC TIRED WHEELS,
ROUGH TERRAIN 6,000 LB CAPACITY, 24 INCH LOAD CENTER
(ANTHONY MODEL MLT-6, ARMY MODEL MHE-200)
NSN 3930-00-903-0900,
(ANTHONY MODEL MLT-6 WITH ROPS)
NSN 3930-01-054-3831,
(CHRYSLER MODEL MLT-6CH, ARMY MODEL MHE-202)
NSN 3930-00-937-0220,
(CHRYSLER MODEL MLT-6CH WITH ROPS)
NSN 3930-01-053-4823,
(ATHEY MODEL ARTFT-6, ARMY MODEL MHE-222)
NSN 3930-00419-5744,
(ATHEY MODEL ARTFT-6 WITH ROPS)
NSN 3930-01-054-3830**

TM 10-3930-242-12, July 1980 is changed as follows:

1. Remove old pages and insert new pages as indicated below.

Remove pages

Pages D-1 through D-7, APPENDIX D

Insert Pages

Pages D-1 through D-14, APPENDIX D

2. File this change sheet in front of the publication for reference purposes.

By Order of the Secretary of the Army:

JOHN A. WICKHAM, JR.
General, United States Army
Chief of Staff

Official:

R.L. DILWORTH
Brigadier General, United States Army
The Adjutant General

Distribution:

To be distributed in accordance with DA Form 12-25 , Operator and Organizational Maintenance requirements for Truck, Lift, Fork, Diesel Engine, Rough Terrain, 6,000 lb. capacity, Model MHE-200, 202, 222.

TECHNICAL MANUAL }
 NO.10-3930-242-12 }

HEADQUARTERS
 DEPARTMENT OF THE ARMY
 WASHINGTON, DC, 31 July 1980

**OPERATOR AND ORGANIZATIONAL MAINTENANCE MANUAL
 FOR**

**TRUCK, LIFT, FORK, DIESEL ENGINE,
 PNEUMATIC TIRED WHEELS, ROUGH TERRAIN**

6,000 LB CAPACITY, 24 INCH LOAD CENTER

(ANTHONY MODEL MLT-6, ARMY MODEL MHE-200)

NSN 3930-00-903-0900

(CHRYSLER MODEL MLT-6CH, ARMY MODEL MHE-202)

NSN 3930-00-937-0220

(ATHEY MODEL ARTFT-6, ARMY MODEL MHE-222)

NSN 3930-00-419-5744

REPORTING ERRORS AND RECOMMENDING IMPROVEMENTS

You can help improve this manual. If you find any mistakes or if you know of a way to improve the procedures, please let us know. Mail your letter, DA Form 2028 (*Recommended Changes to Publications and Blank Forms*), or DA Form 2028-2, located in the back of this manual, direct to: Commander, U.S. Army Tank-Automotive Command, ATTN: AMSTA-MB, Warren, MI 48397-5000. A reply will be furnished to you.

	Paragraph	Page
CHAPTER 1. INTRODUCTION		
Section I. General	1-1-1-5-	1-1
Section II. Description and data	1-6-1-8	1-1
CHAPTER 2. OPERATING INSTRUCTIONS		
Section I. Operating procedures,	2-1-2-5	2-1
Section II. Operation under unusual conditions	2-6-2-13	2-12
CHAPTER 3. OPERATOR/CREW MAINTENANCE INSTRUCTIONS		
Section I. Lubrication instructions	3-1,3-2	3-1
Section II. Preventive maintenance checks and services	3-3,3-4	3-6
Section III. Troubleshooting	3-5	3-8
Section IV. Maintenance procedures.....	3-6-3-13	3-10
CHAPTER 4. ORGANIZATIONAL MAINTENANCE INSTRUCTIONS		
Section I. Service upon receipt of material.....	4-1, 4-2	4-1
Section II. Movement to a new worksite	4-3, 4-4	4-1
Section III. Repair parts, special tools and equipment	4-5,4-6	4-2
Section IV. Preventive maintenance checks and services	4-7,4-8	4-2
Section V. Troubleshooting	4-9,4-10	4-4

1 This manual supersedes TM 10-3930-242-12, 24 December 1973, including all changes.

	Paragraph	Page
VI. Maintenance of lubrication system.	4-11-4-15	4-5
VII. Maintenance of Exhaust system.	4-16,4-17	4-8
VIII. Maintenance of fuel system	4-18-4-22	4-9
IX. Maintenance of cooling system	4-23-4-31	4-14
X. Maintenance of electrical system...	4-32-4-42	4-21
XI. Maintenance of controls and instruments.	4-43-4-52	4-31
XII. Maintenance of transmission.	4-53-4-56	4-35
XIII. Maintenance of propeller shaft	4-57	4-37
XIV. Maintenance of brakes	4-58-4-62	4-38
XV. Maintenance of wheels	4-63	4-41
XVI. Maintenance of steering system.	4-64-4-67	4-42
XVII. Maintenance of hood and body...	4-68-4-70	4-43
XVIII. Maintenance of hydraulic lift, pump, and tubing	4-71-4-77	4-48
APPENDIX A. References	A-1	A-1
B. Components of end items list. (None Authorized)	B-1	B-1
C. Additional authorization list...	C-1	C-1
D. Maintenance allocation chart.	D-1	D-1
E. Repair parts and special tools list (None Authorized)	E-1	E-1
F. Expendable supplies and materials list	F-1	F-1
INDEX		I-1

CHAPTER 1

INTRODUCTION

Section I. GENERAL

1-1. Scope

This manual is for your use in operating and maintaining rough terrain forklift trucks, Army models MHE-200, MHE-202, and MHE-222.

1-2. Maintenance Forms and Records

Equipment maintenance forms, and procedures for their use are contained in DA Pam 738-750.

1-3. Administrative Storage

a. Store equipment to provide maximum protection from the elements and to provide access for inspection, maintenance, and exercising. Anticipate removal or deployment problems and take suitable precautions.

b. Take into account environmental conditions such as extreme heat or cold, high humidity, blowing sand, dust, loose debris, soft ground, mud, heavy snows, and take adequate precautions.

c. Establish a fire plan and provide for adequate fire fighting equipment and personnel.

d. Additional information can be found in TM 740-90-1.

1-4. Destruction of Army Materiel to Prevent Enemy Use

Procedures for the destruction of Army materiel to prevent enemy use are explained in TM 750-244-6.

1-5. Reporting Equipment Improvement Recommendations (EIR)

If your Rough Terrain Fork Lift Truck needs improvement, let us know. Send us an EIR. You, the user, are the only one who can tell us what you don't like about your equipment. Let us know why you don't like the design or performance. Put it on an SF 368 (*Quality Deficiency Report*). Mail it to us at: Commander, U.S. Army Tank-Automotive Command, ATTN: AMSTA-QRD, Warren, MI 48397-5000. We'll send you a reply.

Section II. DESCRIPTION AND DATA

1-6. Description

The rough terrain forklift truck (fig. 1-1 and 1-2) is capable of operating over all types of terrain. It has front and rear axle steering which enables it to move sideways at 20° angles and gives the forklift a shorter turning radius. The forklift can be operated in two-wheel or four-wheel drive, enabling it to travel through mud, snow, sand, and up steep grades with equal mobility. The forklift has fording capability up to five foot waves. The body and forks for the forklift may be tilted right or left in relation to the front axle. The forks are extended by hydraulically operated telescoping arms which reach out, up, or down to handle loads. A hydraulic cylinder moves the forks right or left from center to lift off-center loads. The forklift has expanding tube type hydraulic brakes, hydraulically operated power steering, and a torque converter. The maintenance paragraphs of this manual contain detailed descriptions of its components.

1-7. Tabulated Data

a. *Identification.* The forklift has an identification plate mounted on the left side of the hull which

specifies the nomenclature, shipping dimensions, model number, and engine manufacturer. The data for this plate is listed under tabulated data (b below).

b. Tabulated Data

(1) Corps of Engineers "A" Plate.

Nomenclature. Truck, forklift, diesel, pneumatic tired, 6,000 lb capacity at 24 inch load center

Engine manufacturer. . . . Detroit Diesel

Model. 4-53-N

(2) Dimensions and Weights

Cube 1,763cu ft

Length 228 in.

Width 102 in.

Height 131 in.

Weight:

Anthony and Athey

Empty 23,000 lb

Maximum . . . 29,000 lb

Chrysler

Empty 24,759 lb

Maximum . . . 30,759 lb

Front wheel weights:

Empty 8,645 lb

Loaded 16,952 lb

Rear wheel weights:

- Empty15,915 lb
- Loaded13,608 lb

(3) Capacities.

- Fuel tank 80 gal
- Hydraulic tank 200 qt
- Transmission 24 qt
- Crankcase w/filter 16 qt
- Radiator 25 qt
- Planetary drive 4 qt ea
- Differential 10 qt ea

(4) Wirng diagram. See figure 1-3.

1-8. Differences Among Models

This manual covers the Anthony Model MLT-6 (MHE-200), the Chrysler Model MLT-6CH (MHE-202), and the Athey Model ARTFT-6 (MHE-222). The differences among models exist in the hydraulic cylinders and the common hardware relative to size, length, and type. Cylinder assembly internal parts are not interchangeable on Anthony and Chrysler models, but are interchangeable on Anthony and Athey models. All hydraulic cylinders are interchangeable between models.

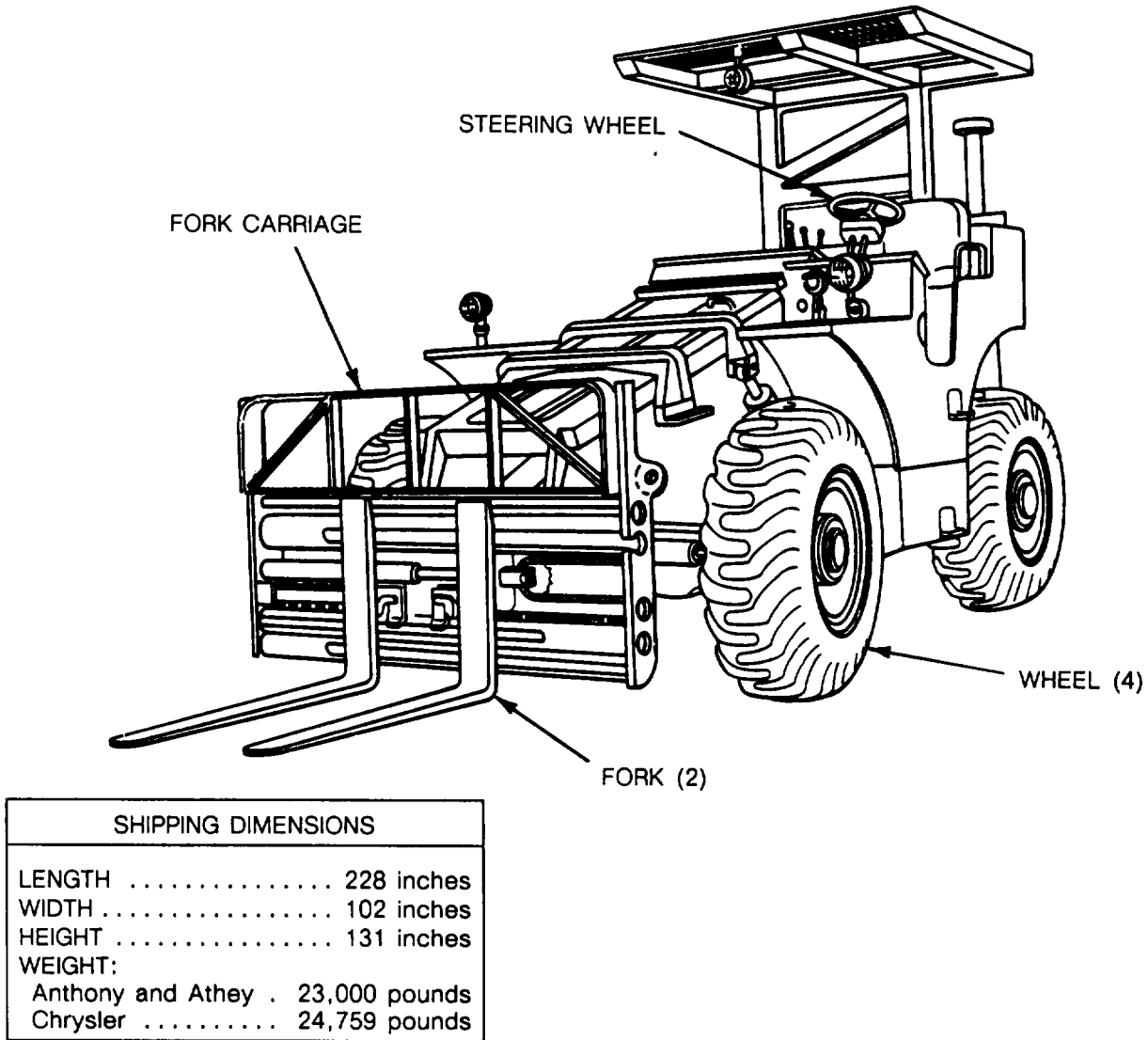

TA501571

Figure 1-1. Rough terrain forklift truck, right front three-quarter view with shipping dimensions.

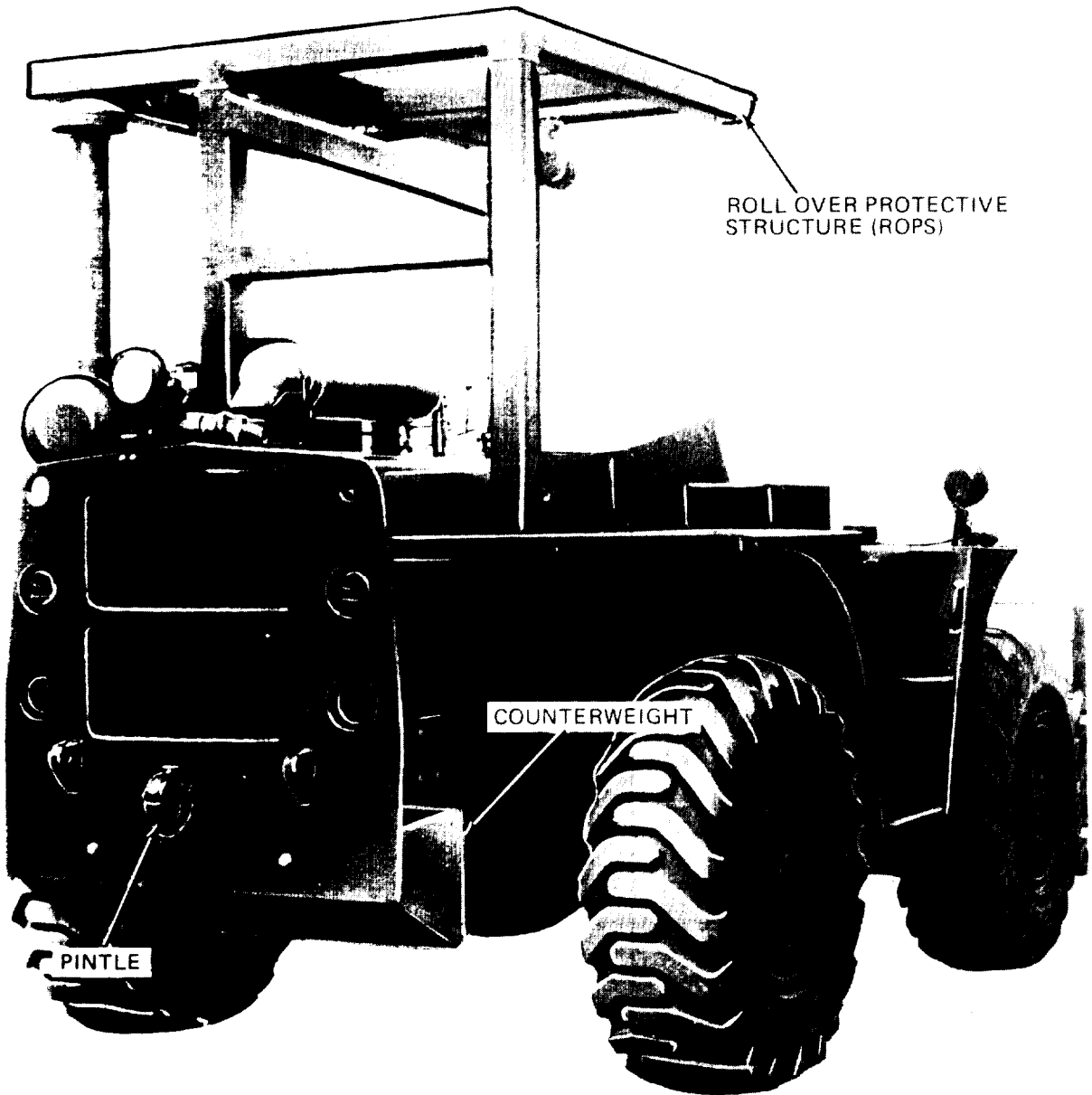

TA031824

Figure 1-2. Rough terrain forklift truck, left rear, three-quarter view.

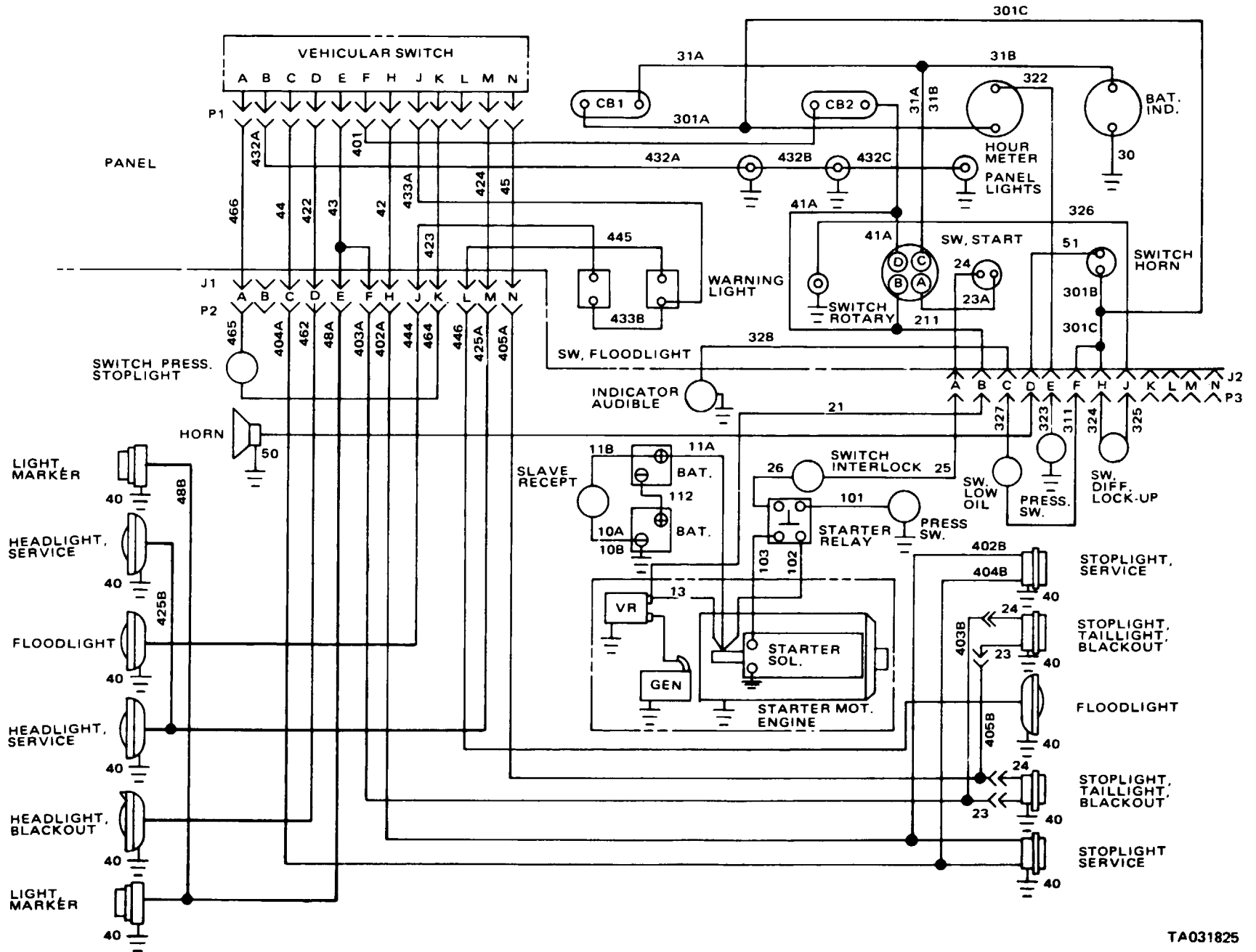

Figure 1-3. Wiring diagram.

CHAPTER 2

OPERATING INSTRUCTIONS

Section I. OPERATING PROCEDURES

WARNING

Operation of this equipment presents a noise hazard to personnel in the area. The noise level exceeds the allowable limits for unprotected personnel. Wear ear muffs or ear plus.

2-1. General

a. The instructions in this section are for the information and guidance, of personnel responsible for the operation of the rough terrain forklift truck.

WARNING

When climbing into the driver's seat, be careful not bump head on roll over protective structure (ROPS).

b. The operator must know how to perform every operation of which the forklift truck is capable. This

section gives instructions on starting, stopping, operating, and coordinating the basic motions to perform the specific tasks for which the forklift is designed. Since nearly every job presents a different problem, the operator may have to vary given procedures to fit the individual job.

c. The outside steering radius of the forklift truck is 32 feet in CRAMP steering mode and 43 feet in the TWO WHEEL steering mode. If steering difficulty is experienced in the CRAMP or CRAB modes of steering, it may be best to continue operation in the TWO WHEEL steering mode.

2-2. Controls and Instrument.

The controls and instruments and their normal readings are illustrated in figure 2-1.

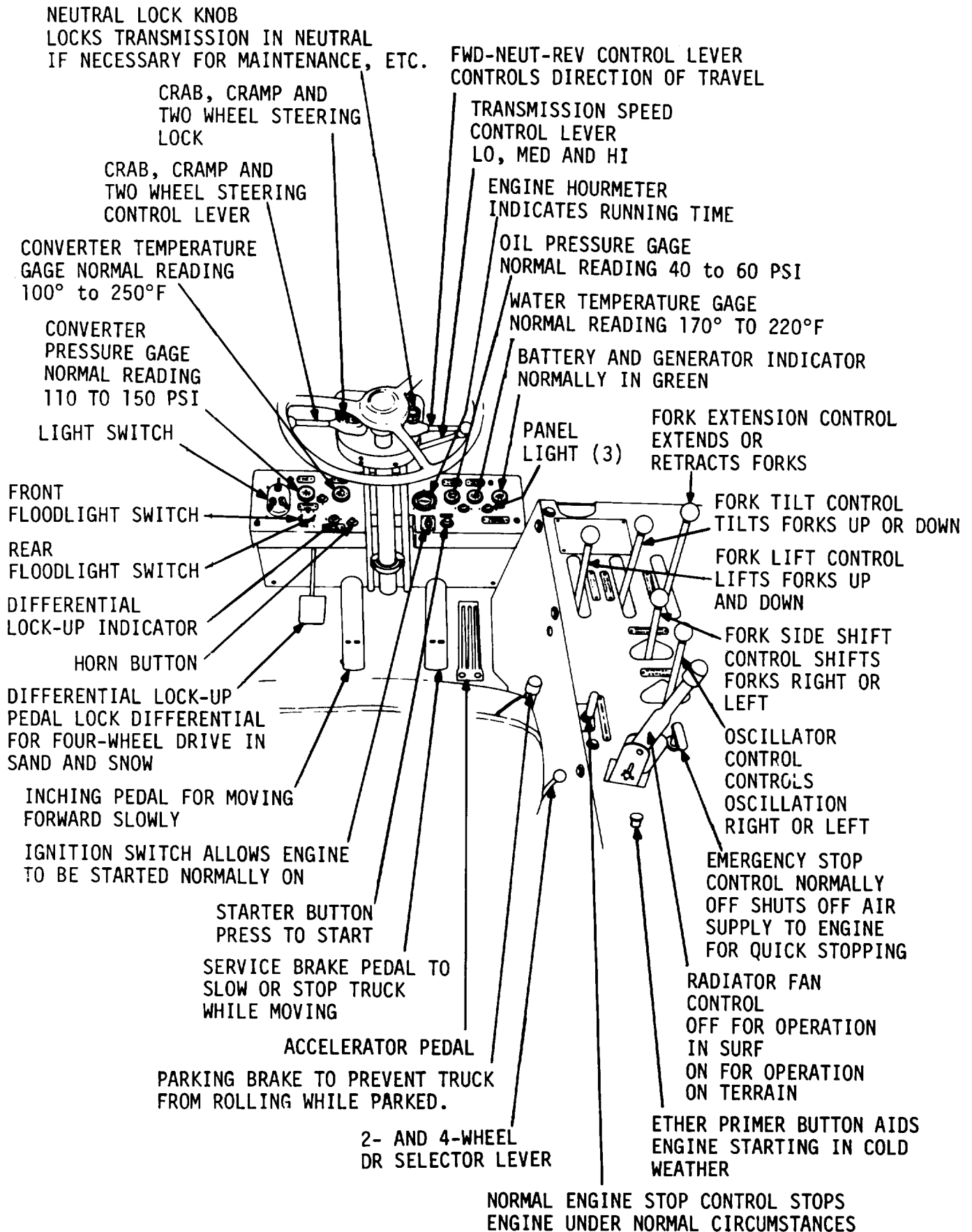

TA072386

Figure 2-1. Controls and instruments.

2-3. Starting

a. *Preparation for Starting.* Perform the before operation services in table 3-1.

NOTE

Starting circuit is operative only when FWD NEUT REV control lever is in NEUT.

b. *Starting.* Refer to figure 2-2 and start the forklift.

CAUTION

Continue operation only if there is not an apparent loss of hydraulic oil or no unusual noise from the hydraulic pump to prevent damage to the forklift.

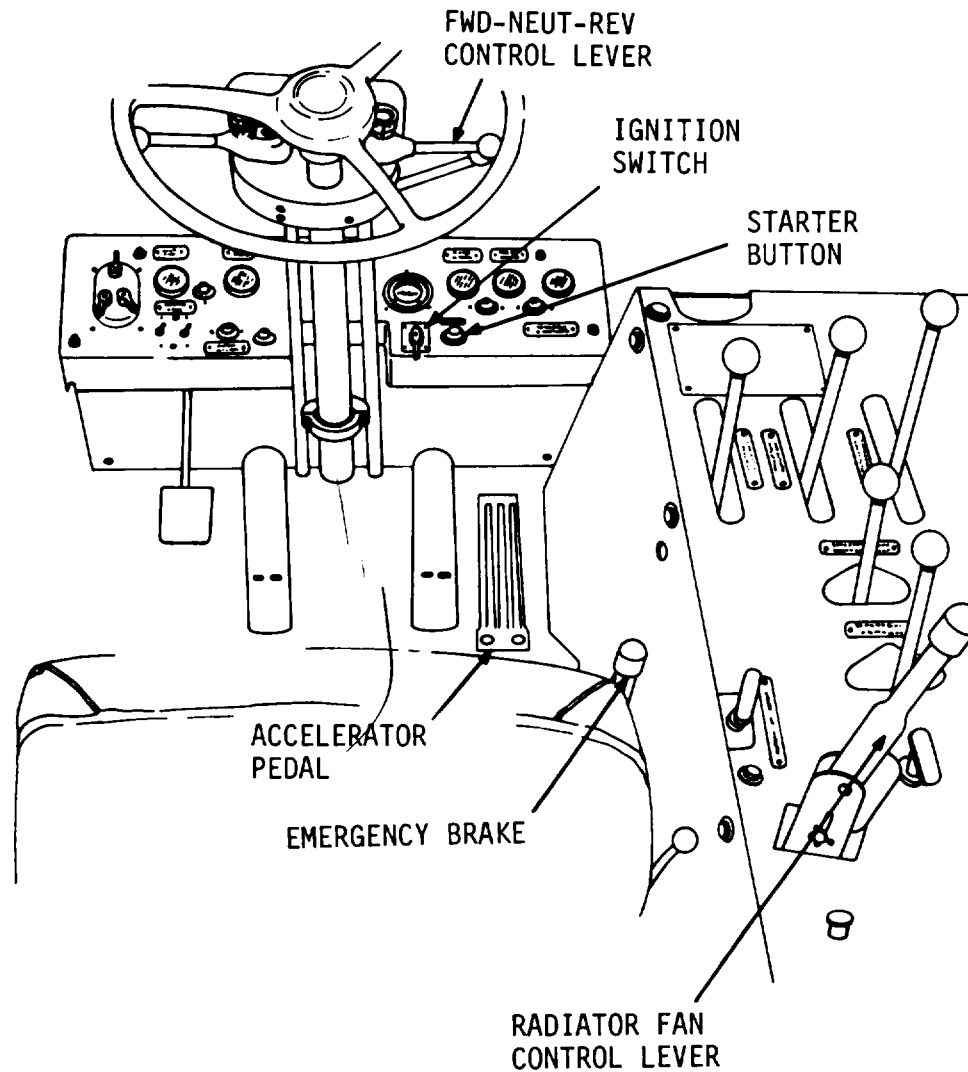

- STEP 1: PLACE FWD-NEUT-REV LEVER IN NEUT POSITION.
- STEP 2: ENGAGE PARKING BRAKE.
- STEP 3: CHECK RADIATOR FAN CONTROL LEVER FOR PROPER POSITION.
- STEP 4: PLACE IGNITION SWITCH IN ON POSITION.
- STEP 5: PRESS ACCELERATOR PEDAL DOWN ONE THIRD DISTANCE.
- STEP 6: PRESS STARTER BUTTON.
- STEP 7: WARM ENGINE FOR THREE TO FIVE MINUTES AND OBSERVE INSTRUMENTS FOR NORMAL READING (FIG. 2-1).
- STEP 8: REMOVE FOOT FROM ACCELERATOR PEDAL.

TA072307

Figure 2-2. Engine starting instructions.

2-4. Operation of Equipment

WARNING

Do not attempt to cross a side slope of 30° or more with forklift in FOUR WHEEL steering mode because the forklift may turn over.

a. General. The rough terrain forklift truck is capable of operating over all types of terrain such as

snow, sand, and steep grades with equal mobility.

b. Driving on Improved Surfaces. Refer to figure 2-3 for driving instructions while operating on improved surfaces. After you put the drive selector lever in TWO WHEEL DR, place the CRAB, CRAMP, and TWO WHEEL steering control lever in the TWO WHEEL steering position and engage the TWO WHEEL steering lock.

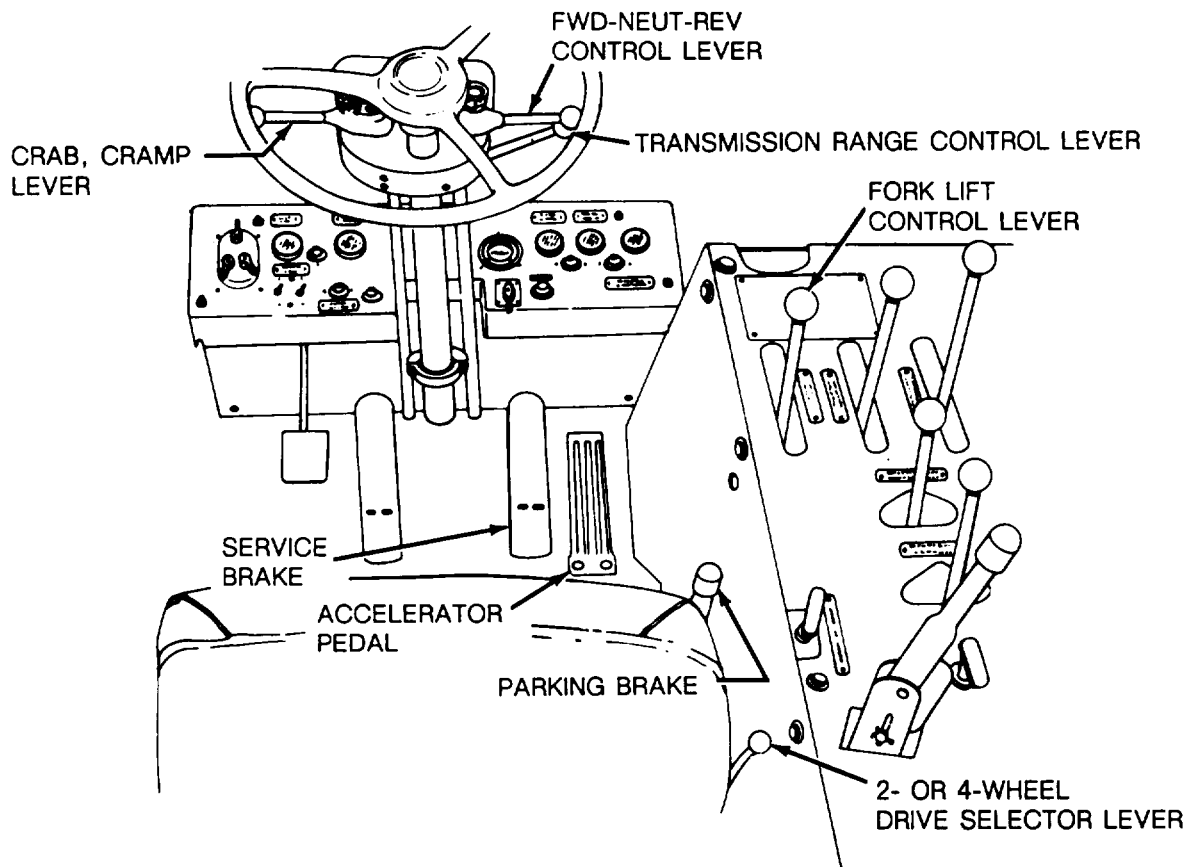

- STEP 1: START ENGINE (REF. PARA. 2-3).
- STEP 2: PULL FORK LIFT CONTROL LEVER TO RAISE FORKS 12 TO 18 INCHES OFF OPERATING SURFACE.
- STEP 3: PLACE DRIVE SELECTOR LEVER (LOCATED TO REAR OF PARKING BRAKE) IN TWO-WHEEL DRIVE POSITION.
- STEP 4: DISENGAGE PARKING BRAKE AND APPLY SERVICE BRAKES.
- STEP 5: PLACE TRANSMISSION RANGE CONTROL LEVER IN DESIRED POSITION, DEPENDING ON WEIGHT OF LOAD. PLACE FWD-NEUT-REV CONTROL LEVER IN DESIRED POSITION.
- STEP 6: RELEASE SERVICE BRAKES.
- STEP 7: PRESS ACCELERATOR PEDAL AND PROCEED.

TA501572

Figure 2-3 Driving on improved surfaces.

c. *Driving on Unimproved Surfaces.* Refer to figure 2-4 for driving instructions in surf. Refer to

figure 2-5 for instructions for driving in snow or sand.

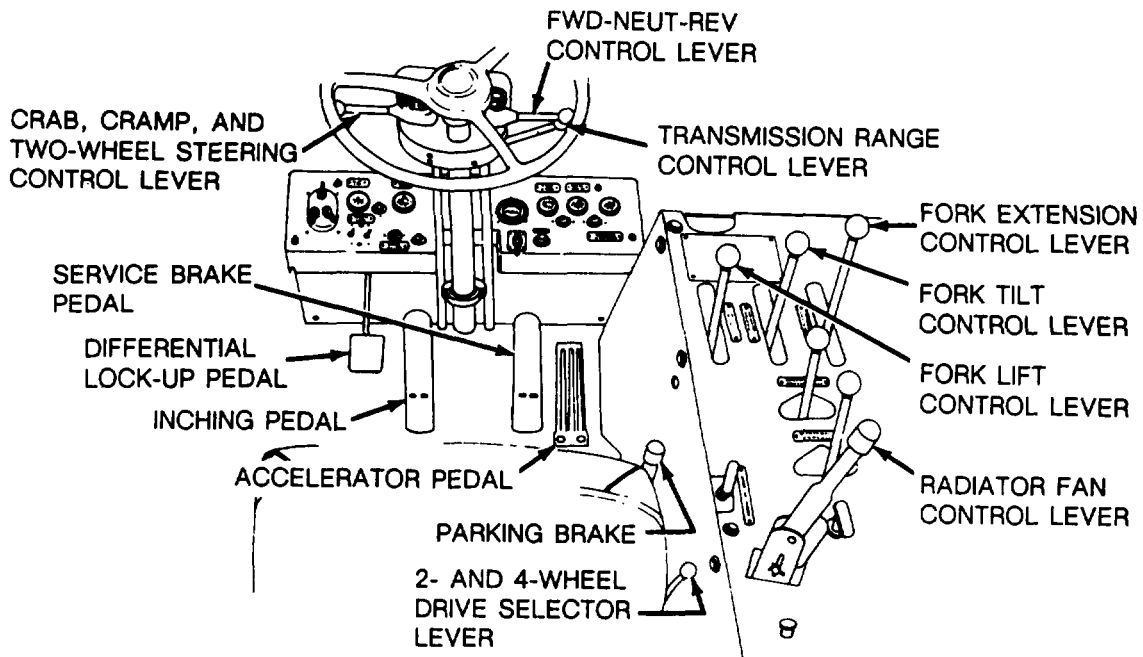

NOTE: MAKE SURE FLYWHEEL HOUSING DRAIN PLUG IS IN PLACE, AND START ENGINE (FIG. 2.2).

STEP 1: PULL FORK LIFT CONTROL LEVER TO RAISE FORKS JUST HIGH ENOUGH TO CLEAR THE SURF.

NOTE: IF TRANSPORTING A LOAD, PULL FORK EXTENSION CONTROL LEVER BACK TO RETRACT LOAD AS CLOSE TO CENTER OF TRUCK AS POSSIBLE TO BALANCE LOAD.

STEP 2: PLACE DRIVE SELECTOR LEVER (LOCATED TO REAR OF PARKING BRAKE) IN FOUR-WHEEL DRIVE POSITION.

STEP 3: RELEASE PARKING BRAKE AND APPLY SERVICE BRAKES.

STEP 4: PLACE TRANSMISSION RANGE CONTROL LEVER IN DESIRED POSITION. NORMALLY A LOW-SPEED POSITION IS REQUIRED FOR SURF OPERATION.

STEP 5: PLACE FWD-NEUT-REV CONTROL LEVER IN POSITION FOR DESIRED DIRECTION OF TRAVEL.

STEP 6: RELEASE SERVICE BRAKE, PRESS ACCELERATOR PEDAL AND PROCEED.

NOTE: JUST BEFORE ENTERING SURF, PLACE RADIATOR FAN CONTROL LEVER IN OFF POSITION. WHEN LEAVING SURF, PLACE RADIATOR FAN CONTROL LEVER IN ON POSITION.

CAUTION: DO NOT ALLOW WATER TO EXCEED 5-FOOT LEVEL MARK, MEASURED FROM CREST OF WAVES. PROCEED SLOWLY THROUGH SURF, KEEPING CONSTANTLY ALERT FOR HOLES AND OCEAN BOTTOM SOFTNESS. WHEN TIDE IS OUT, BOTTOM IS ESPECIALLY SOFT. IF TRUCK BEGINS TO MIRE, DO NOT STOP: MANEUVER UNTIL FREE. DIFFERENTIAL LOCK MAY BE USED WHEN NECESSARY TO GAIN ADDITIONAL TRACTION.

STEP 7: OBSERVE RAMP OF LANDING CRAFT BEFORE ENTERING. ENTER FROM CENTER OF RAMP ON WAVE RATHER THAN BETWEEN WAVES TO COMPENSATE FOR SHIFTING. KEEP SIGHT ON TOP OF LEFT FORK. USE FORK TILT CONTROL LEVER TO BALANCE LOAD WHEN GOING UP OR DOWN RAMP.

CAUTION: BRAKES ARE LESS EFFECTIVE IMMEDIATELY AFTER LEAVING SURF.

NOTE: IF CONDITIONS WARRANT THE USE OF FOUR-WHEEL STEERING, ALINE FRONT WHEELS, PLACE FWD-NEUT-REV CONTROL LEVER IN FORWARD POSITION AND PLACE CRAB AND CRAMP CONTROL LEVER IN DESIRED POSITION:

NOTE: CRAMPING IS NOT RECOMMENDED FOR SOFT TERRAIN.

NOTE: AFTER OPERATION IN SURF, SEE LO 10-3930-242-12-1, NOTE 6 AND NOTE 7.

TA501735

Figure 2-4. Driving in surf

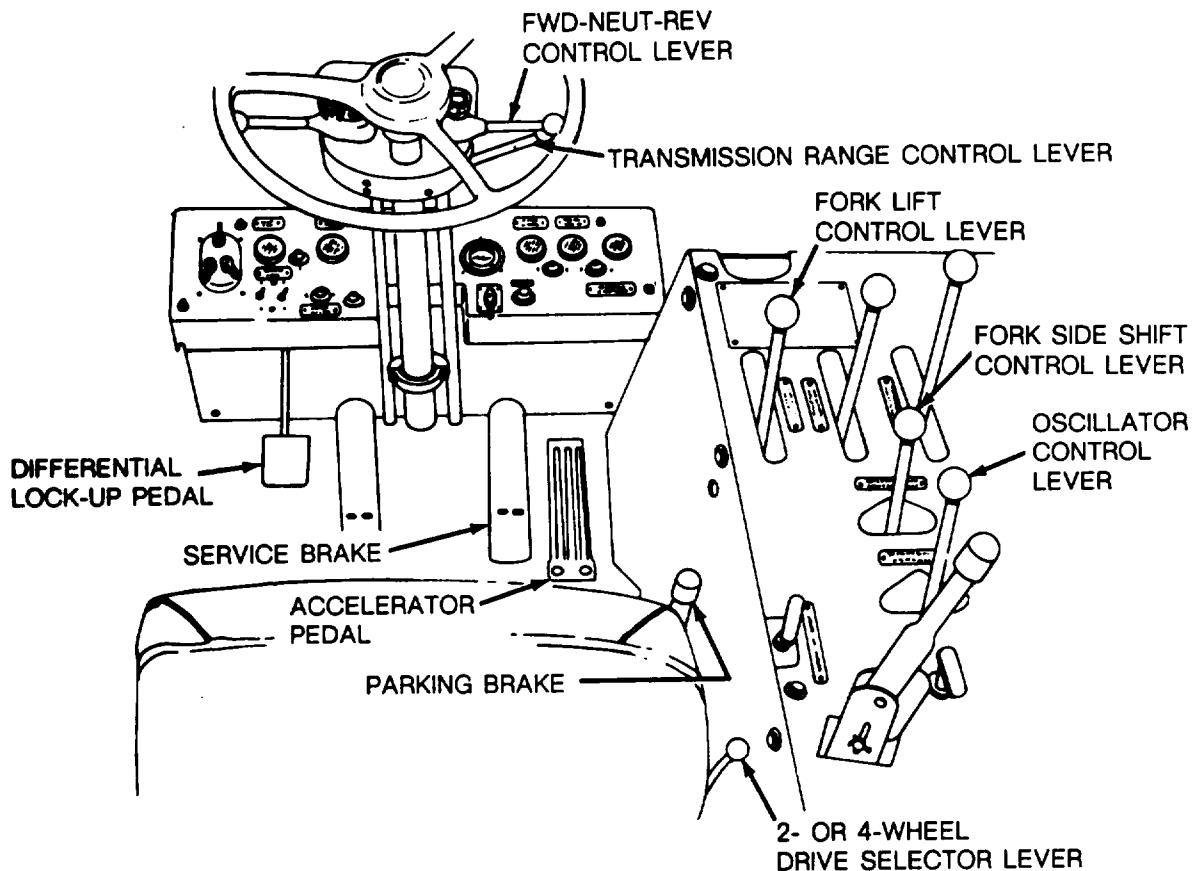

- NOTE: START ENGINE (FIG. 2-2).
- STEP 1: PULL FORK LIFT CONTROL LEVER TO RAISE FORKS 12 TO 18 INCHES ABOVE OPERATING SURFACE.
- STEP 2: PLACE DRIVE SELECTOR LEVER (LOCATED TO REAR OF PARKING BRAKE) IN 4-WHEEL DRIVE .
- STEP 3: RELEASE PARKING BRAKE AND APPLY SERVICE BRAKE .
- STEP 4: PLACE TRANSMISSION RANGE CONTROL LEVER IN POSITION FOR DESIRED SPEED, DEPENDING ON WEIGHT OF LOAD AND TERRAIN CONDITIONS.
- STEP 5: PLACE FWD-NEUT-REV CONTROL LEVER IN POSITION FOR DESIRED DIRECTION OF TRAVEL.
- STEP 6: RELEASE SERVICE BRAKE, PRESS ACCELERATOR PEDAL AND PROCEED.
- NOTE: DRIVE IN TRACKS ALREADY MADE IF POSSIBLE.
- STEP 7: IF FEASIBLE, APPROACH SAND DUNES DIRECTLY (AT RIGHT ANGLES). ATTEMPTS TO SCALE AN INCLINE SIDWAYS AND UPWARD USUALLY RESULT IN DOWNWARD SLIPPAGE. IF A DIRECT APPROACH CANNOT BE MADE, USE THE OSCILLATION CONTROL LEVER TO BALANCE LOAD DURING THE ASCENT.
- WARNING:** DO NOT ATTEMPT TO CROSS A SLOPE OF 30° OR MORE BECAUSE THE TRUCK MAY OVERTURN.
- NOTE: DIFFERENTIAL LOCK MAY BE USED WHEN NECESSARY TO GAIN ADDITIONAL TRACTION IN SAND OR SNOW.

TA501736

Figure 2-5. Driving in sand or snow.

d. *Picking up Load on Improved Surfaces.* Refer to figure 2-6 for instructions.

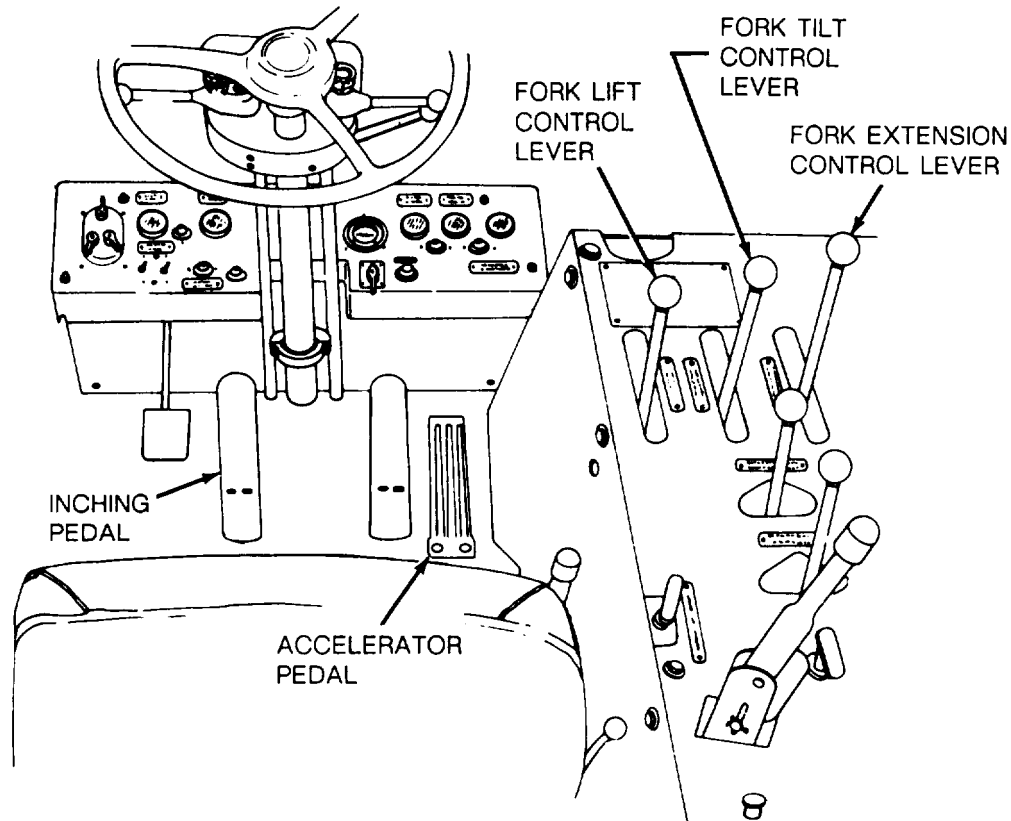

NOTE: LOAD CARRY POSITION SHOULD BE 20-24 INCHES ABOVE THE GROUND TO THE HEEL OF FORKS AND 21-23 INCHES FROM TREAD OF FRONT TIRE TO THE HEEL OF FORKS. INNER AND OUTER BOOM SHOULD BE MARKED AT THIS POINT FOR QUICK OPERATOR REFERENCE.

- STEP 1: APPROACH LOAD SQUARELY WITH LIFT FORKS AT CORRECT HEIGHT AND SPACED TO DIVIDE LOAD EVENLY. BE SURE LOCK ASSEMBLIES ARE SECURE IN THE CHAIN, AND THAT THE SPECIAL LOCK HANDLES ARE IN THE LOCKED POSITION.
- STEP 2: DEPRESS INCHING PEDAL ABOUT HALFWAY TO MOVE FORWARD SLOWLY UNTIL LIFT FORKS ARE COMPLETELY UNDER LOAD.
- STEP 3: DEPRESS INCHING PEDAL FULLY TO NEUTRALIZE TRANSMISSION.
- STEP 4: ACCELERATE ENGINE SLIGHTLY, NOT MORE THAN 1/2 THROTTLE OR APPROXIMATELY 1500 RPM.
- STEP 5: PULLBACK FORK LIFT CONTROL LEVER AND PICK UPLOAD.
- STEP 6: PULLBACK FORK TILT CONTROL LEVER TO TILT LOAD AND PREVENT ITS SLIPPING FROM LIFT FORKS.
- STEP 7: PULLBACK FORK EXTENSION CONTROL LEVER TO RETRACT LOAD TO CARRY POSITION AND BETTER BALANCE TRUCK.

TA501573

Figure 2-6. Picking up load on improved surfaces.

e. *Picking up Load on Unimproved Surfaces.*
Refer to figure 2-7 for instructions.

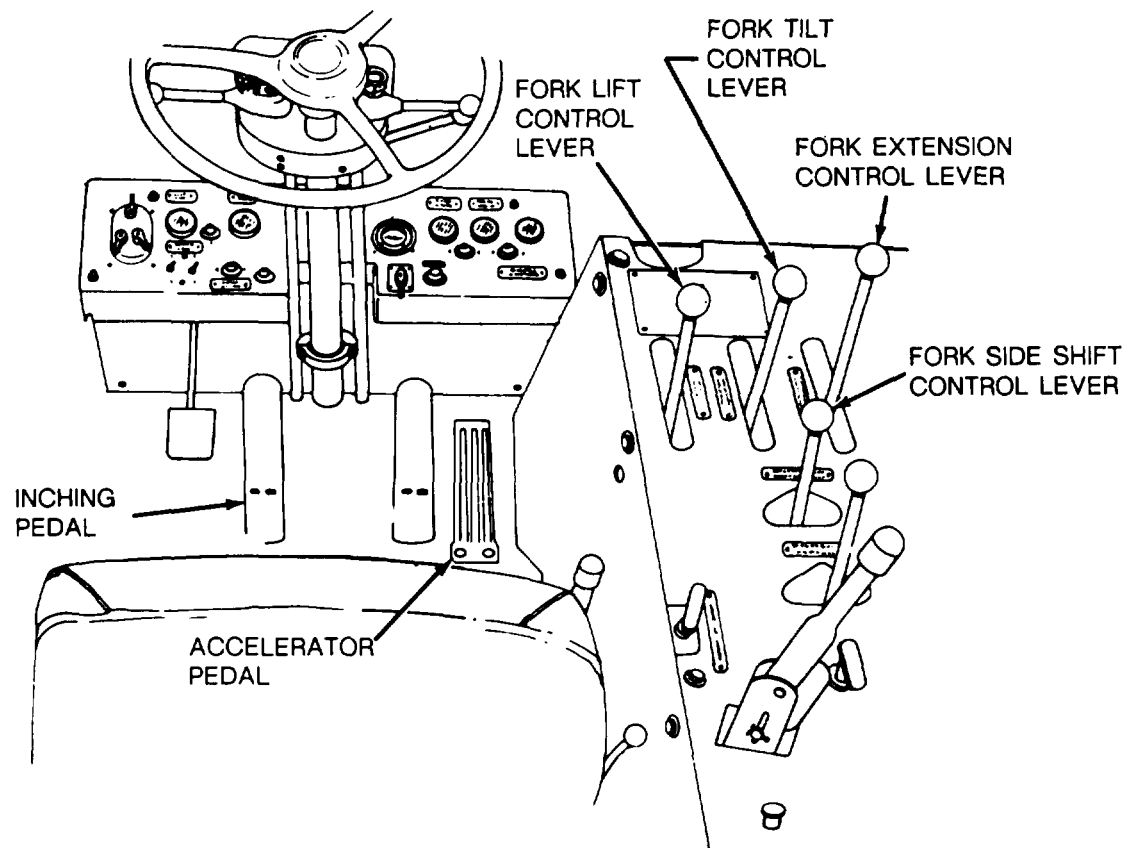

NOTE: LOAD CARRY POSITION SHOULD BE 20-24 INCHES ABOVE THE GROUND TO THE HEEL OF FORKS AND 21-23 INCHES FROM TREAD OF FRONT TIRE TO THE HEEL OF FORKS. INNER AND OUTER BOOM SHOULD BE MARKED AT THIS POINT FOR QUICK OPERATOR REFERENCE.

- STEP 1: APPROACH LOAD SQUARELY AND STOP TRUCK (FIG. 2-9), LEAVING AMPLE ROOM TO MAKE FORK ADJUSTMENTS.
- STEP 2: PUSH FORK EXTENSION CONTROL LEVER FORWARD TO EXTEND FORKS LONGITUDINALLY.
- STEP 3: PUSH FORK TILT CONTROL LEVER FORWARD TO TILT FORK CARRIAGE TO VERTICAL POSITION.
- STEP 4: PUSH FORK LIFT CONTROL LEVER FORWARD AND LOWER FORKS TO CORRECT HEIGHT. SEE THAT FORKS ARE SPACED TO DIVIDE LOAD EVENLY, IF NECESSARY, USE FORK SIDE SHIFT CONTROL LEVER TO PROPERLY POSITION FORKS FROM SIDE TO SIDE.
- STEP 5: DEPRESS INCHING PEDAL ABOUT HALFWAY TO DRIVE TRUCK FORWARD SLOWLY UNTIL FORKS ARE COMPLETELY UNDER LOAD.
- STEP 6: DEPRESS INCHING PEDAL FULLY TO NEUTRALIZE THE TRANSMISSION AND ACCELERATE THE ENGINE NOT MORE THAN 1/2 THROTTLE OR APPROXIMATELY 1500 RPM.
- STEP 7: PULLBACK FORK LIFT CONTROL LEVER AND PICK UPLOAD.
- STEP 8: PULLBACK FORK TILT CONTROL LEVER TO TILT LOAD AND PREVENT ITS SLIPPING FROM FORKS.
- STEP 9: PULLBACK FORK EXTENSION CONTROL LEVER TO RETRACT LOAD TO CARRY POSITION AND BETTER BALANCE TRUCK.

TA501574

Figure 2-7. Picking upload on unimproved surfaces.

f. Depositing Load. Refer to figure 2-8 for instructions.

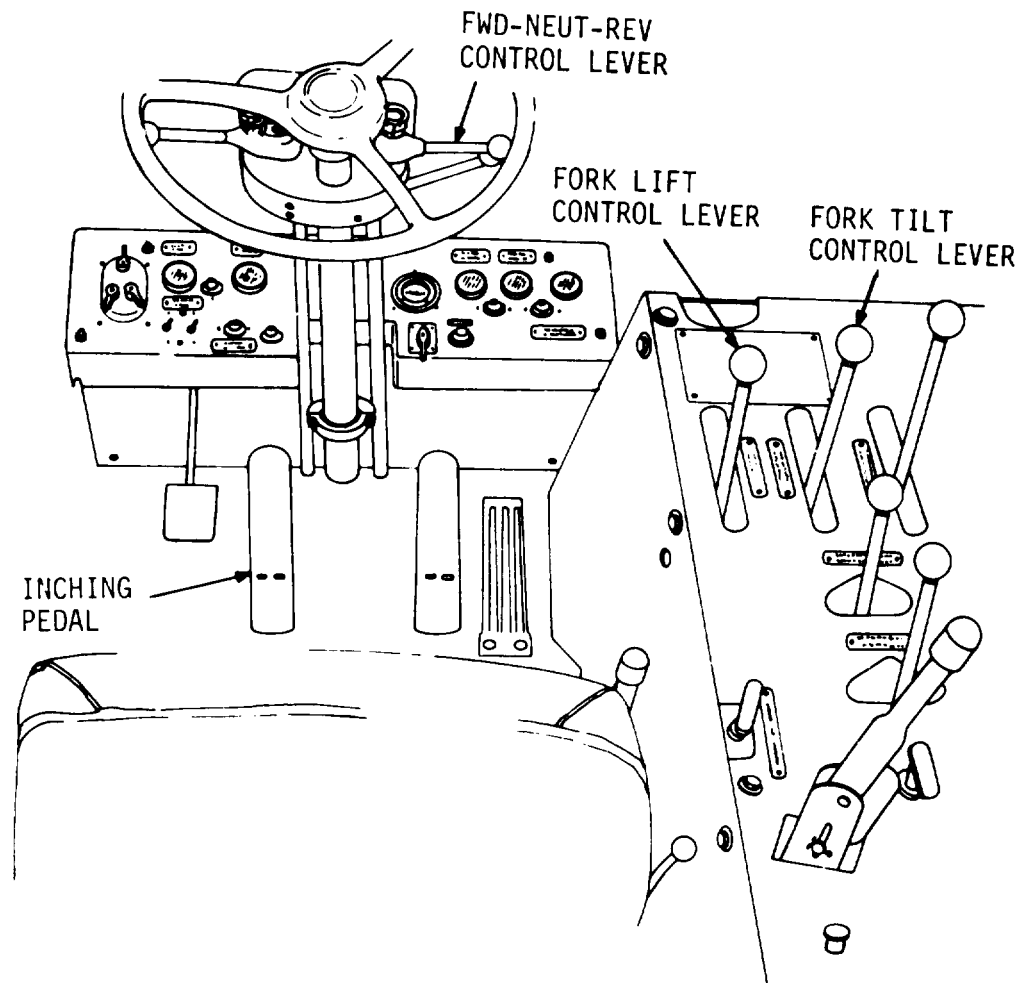

- STEP 1: CAREFULLY DRIVE UP TO POSITIO WHERE LOAD IS TO BE DEPOSITED.
- STEP 2: DEPRESS INCHING PEDAL.
- STEP 3: PUSH FORK EXTENSION CONTROL LEVER FORWARD TO EXTEND FORKS LONGITUDINALLY.
- STEP 4: PUSH FORK TILT CONTROL LEVER FORWARD TO TILT CARRIAGE TO VERTICAL POSITION.
- STEP 5: IF LOAD IS TO BE DEPOSITED ON GROUND LEVEL, PUSH FORK LIFT CONTROL LEVER FORWARD AND ALLOW LOAD TO LOWER SLOWLY TO RESTING PLACE. CONTINUE TO LOWER FORKS UNTIL THEY CAN BE EASILY WITHDRAWN FROM PALLET. THEN PROCEED WITH STEP 10.
- STEP 6: IF LOAD IS TO BE DEPOSITED ON A TIERED STACK, PULL FORK LIFT CONTROL LEVER BACK UNTIL LOAD REACHES DESIRED HEIGHT ABOVE TIER, THEN PROCEED WITH STEPS 7 THROUGH 10.
- STEP 7: RELEASE INCHING PEDAL ABOUT HALFWAY AND INCH TRUCK FORWARD UNTIL LOAD IS ABOVE ITS RESTING PLACE.
- STEP 8: DEPRESS INCHING PEDAL.
- STEP 9: PUSH FORK LIFT CONTROL LEVER FORWARD AND LOWER LOAD CAREFULLY TO ITS RESTING PLACE. CONTINUE TO LOWER FORKS UNTIL THEY CAN BE EASILY WITHDRAWN FROM PALLET.
- STEP 10: PLACE FWD-NEUT-REV CONTROL LEVER IN REV AND RELEASE INCHING PEDAL.

TA072391

Figure 2-8. Depositing load.

2-5. Stopping

a. *Normal Stopping.* Refer to figure 2-9 for stopping instructions.

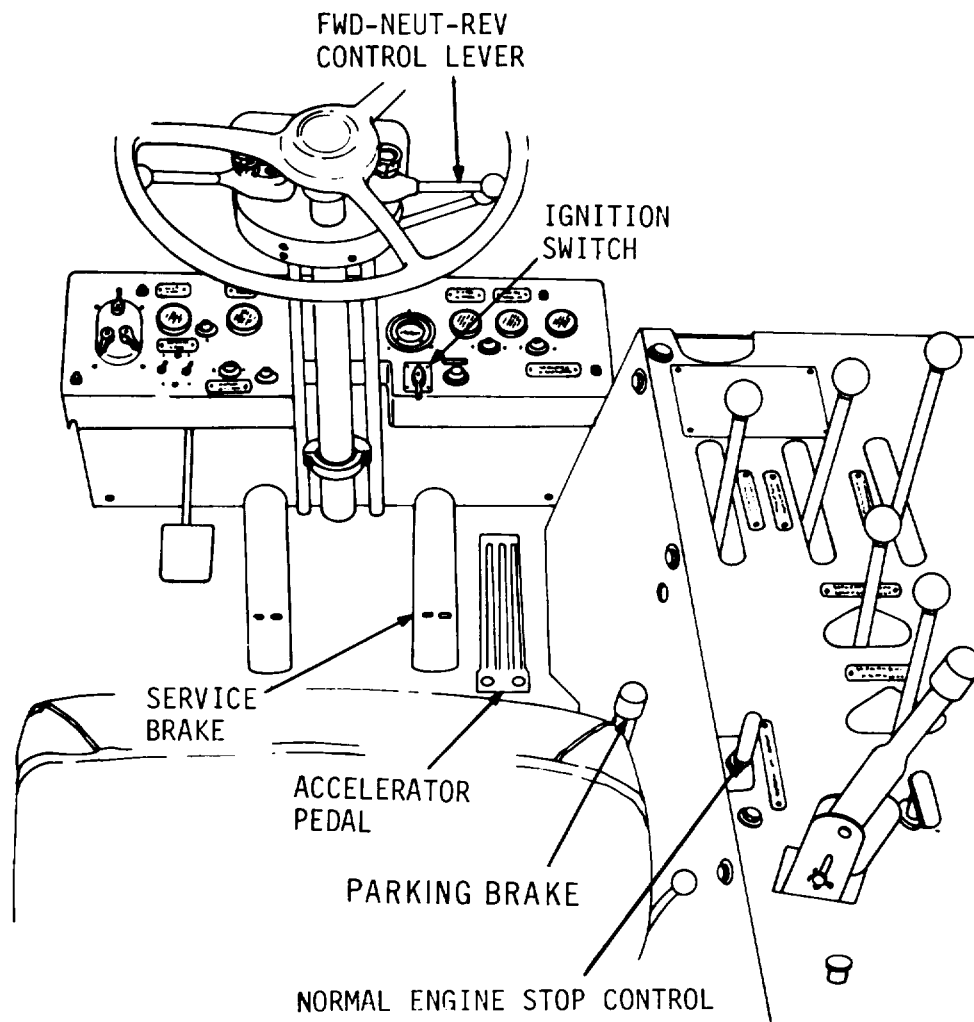

- STEP 1: REMOVE FOOT FROM ACCELERATOR.
- STEP 2: DEPRESS BRAKE PEDAL SLOWLY AND BRING TRUCK TO GRADUAL STOP.
- STEP 3: PLACE FWD-NEUT-REV CONTROL LEVER IN NEUT POSITION.
- STEP 4: IF TRUCK IS TO BE PARKED, APPLY PARKING BRAKE, ALLOW ENGINE TO IDLE 3-5 MINUTES THEN PULL UP ON NORMAL ENGINE SHUTOFF HANDLE.
- STEP 5: TURN OFF IGNITION SWITCH.

TA072392

Figure 2-9. Forklifts topping instructions.

b. *Emergency Stopping.* Pull up on the EMERGENCY STOP CONTROL to stop the engine in emergency.

NOTE

To restart the engine after the EMERGENCY STOP CONTROL has been used, push the EMERGENCY

STOP CONTROL down. The EMERGENCY STOP CONTROL reset lever, located on left side of engine must be pushed toward the cylinder block.

Section II. OPERATION UNDER UNUSUAL CONDITIONS

2-6. Operation in Extreme Cold (below 0°F. (-18° C))

- a. Check coolant level and add coolant as specified in table 2-1. Have organizational maintenance perform specific gravity test to make sure that antifreeze solution is correct for lowest temperature expected.
- b. Inspect cooling system. Correct or report any leaks.
- c. Keep batteries fully charged. After adding distilled water to the batteries, run the engine for at least 15 minutes.
- d. Keep fuel tank full when not in operation.
- e. Drain secondary fuel filters of water and

- foreign materials. If fuel filters require servicing, report to organizational maintenance.
- f. Lubricate in accordance with current lubrication chart (fig. 3-1).
- g. Pull up on either primer button, engage starter, and with the engine turning, press the ether button down. If combustion does not occur, repeat the priming process with the starter engaged.
- h. In extremely cold weather it is advisable to give the engine one priming charge before engaging the starter. Then proceed as in g above.
- i. Allow the engine to reach normal operating temperature before applying load.

Table 2-1. Freezing Points, Composition, and Specific Gravities of Military Antifreeze Material

Lowest expected ambient temp °F.	Pints of inhibited glycol per gallon of coolant ¹	Compound, antifreeze ²	Ethylene glycol coolant solution specific gravity at 68° F. ³
+20	1½	Issued full strength and ready mixed for 0 to -65° F temperatures for both installation and losses.	1.022
+10	2		1.036
0	2¾		1.047
-10	3¼		1.055
-20	3½		1.062
-30	4		1.067
-40	4 ½		1.073
-50	Arctic antifreeze preferred		

¹Maximum protection is obtained at 60 percent by volume (4.8 pints of ethylene glycol per gallon of solution).

²Military Specification M IL-C-11755 Arctic type, non-volatile antifreeze compound is intended for use in the cooling system of liquid cooled internal combustion engines. It is used for protection against freezing primarily in Arctic regions where the ambient temperature remains for extended periods of time close to - 40° F., or below, to as low as - 90° F.

³Use an accurate hydrometer. To test hydrometer, use 1 part ethylene glycol type antifreeze to 2 parts water. This should produce a hydrometer reading of 0° F.

2-7. Starting Aid

a. *General* The starting aid is a pressurized system used to inject a highly volatile fluid into the engine air intake system. This is to facilitate starting when ambient temperatures are below 40° F. The replaceable pressurized cylinder contains sufficient fluid for 75-150 starts.

b. *Operating the Starting Aid.*

- (1) Operate starting aid control for about 2 seconds. Wait 3 seconds before cranking engine.

- (2) perform normal starting procedures (para 2-3).

- (3) If engine fails to start, refer to troubleshooting table (table 3-2).

2-8. Operation in Extreme Heat WARNING

Be extremely careful when removing the radiator filler cap of a hot engine. Release of pressure may cause violent boiling and serious injury to personnel.

a. Insure that radiator filler cap seals properly. The boiling point of the coolant is raised as the system pressure is increased.

b. Check coolant level frequently and add coolant as necessary. Use standard ethylene glycol mixture as specified in table 2-1.

c. Remove all obstructions and foreign material collected on radiator fins and air passages.

d. Do not overfill fuel tank. Make sure fuel filters are clean.

WARNING

If NBC exposure is suspected, all air filter media should be handled by personnel wearing protective equipment. Consult your unit NBC Officer or NBC NCO for appropriate handling or disposal procedures.

e. Have air cleaner cleaned and serviced.

2-9. operation in Dusty or Sandy Area

a. Clean all grease fittings after operation.

b. Lubricate in accordance with figure 3-1.

c. Check oil filter and engine oil frequently.

d. Have air cleaner serviced often.

e. Have fuel filters cleaned and serviced.

2-10. Operation in Salt Water Area

a. Keep all lubrication points clean and well lubricated.

b. Keep all wiring and ignition terminals free of corrosion.

c. Keep forklift as clean as possible.

d. After operation is complete, wash with fresh water. Lubricate in accordance with figure 3-1. Check all gear cases for water contamination. If contamination is found, (evidenced by a milky color of lubricant) drain, flush, and refill.

2-11. Operation Under Rainy or Humid Conditions

a. Keep fuel tank full at all times.

b. Wash forklift truck after operation.

2-12. Operation at High Altitude

a. Check coolant level frequently and add coolant as necessary.

NOTE

The engine will operate less efficiently at high altitudes.

b. Observe engine instruments while operating for any indication of trouble.

2-13. Operation in Snow

a. Keep fuel tank full at all times. Keep snow away from filler where servicing fuel tank.

b. Clean all snow from operating controls and from steps.

CHAPTER 3

OPERATOR/CREW MAINTENANCE INSTRUCTIONS

Section I. LUBRICATION INSTRUCTIONS

WARNING

Drycleaning solvent, P-D-680, used to clean parts is potentially dangerous to personnel and property. Do not use near open flame or excessive heat. The flash point of solvent is 138° F.

3-1. General Lubrication Information

This section contains information on lubrication instructions not covered in the current lubrication order. Refer to the current lubrication order for all other instructions.

3-2. Detailed Lubrication Information

a. Care of Lubricants. Keep all lubricants in closed containers and store in a clean, dry place, away from heat. Keep container cover clean and in good condition. Keep dust, dirt, and all other foreign material out of the lubricant. Keep all lubrication

equipment clean and ready for use.

b. Cleaning. Keep all external parts, that do not require lubrication, free of lubricants. Wipe all lubrication points clean before lubricating the forklift truck. Clean all lubrication points of excessive lubricant after servicing to prevent a build-up or accumulation of foreign matter.

CAUTION

Excessive lubrication may cause equipment failure or damage to movable parts.

c. Points of Lubrication. Service the forklift truck at the intervals given in figure 3-1.

d. Intervals of Lubrication. The intervals of lubrication specified in the lubrication order chart (fig. 3-1) are based on operation under normal conditions. Modifications of these recommended intervals may be required under unusual operating conditions.

**LUBRICATION
ORDER**

LO10-3930-242-12-1

(Supersedes LO10-3930-242-12-1 dated 31 MAY 1974)

**TRUCK, LIFT, FORK, DIESEL ENGINE, PNEUMATIC TIRED WHEELS,
ROUGH TERRAIN, 6000 LB CAPACITY, 24 INCH LOAD CENTER,
(ANTHONY MODEL MLT-6) (ARMY MODEL MHE 200)
(CHRYSLER MODEL MLT-6CH) (ARMY MODEL MHE
202) (ATHEY MODEL ARTFT-6) (ARMY MODEL
MHE 222) W/DETROIT DIESEL ENGINE
MODEL 5043-7000**

Reference: LO10-3930-242-12-2 and FEDERAL SUPPLY CATALOG C9100-IL

Intervals are based on normal hours of operation. Adjust to compensate for abnormal operation and severe conditions. During inactive periods, sufficient lubrication must be performed for adequate preservation.

Clean fittings before lubricating.

Relubricate after washing or fording.

A dotted circle indicates a drain below.

Clean parts with SOLVENT, dry-cleaning, Type 11 (SD-2). Dry before lubricating.

Lubricate points, indicated by dotted arrow shafts on both sides of equipment.

Drain gearcases when hot. Fill and check level.

*The time specified is the time required to perform all services at the particular interval.

* TOTAL MAN-HR		* TOTAL MAN-HR	
INTERVAL	MAN-HR	INTERVAL	MAN-HR
10	.4	250	.4
50	.4	500	1.3
100	1.0	1000	1.3

FOLD

FOLD

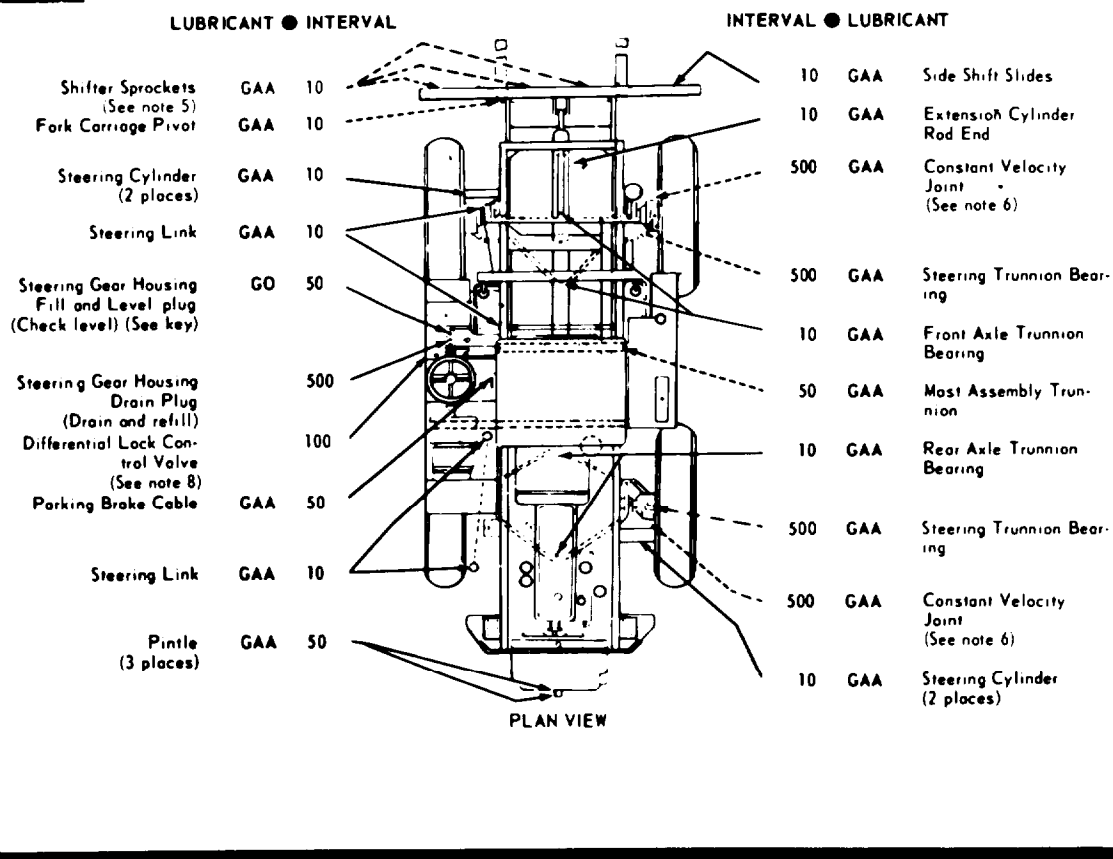

Figure 3-1. LO 10-3930-242-12-1/2 (Sheet 1 of 4)

TA157257

LUBRICANT ● INTERVAL

Front Wheel Hub Fill and Drain Plug (Drain and refill) (See notes 4 and 7) (See key) GO 1000

Front Wheel Hub Level Plug (Check level) (See note 4) 50

Propeller Shafts Splines and Bearings (Sprangly with hand gun) Disconnect Linkage (See note 10) GAA 50

Rear Wheel Hub Fill and Drain Plug (See key) (Drain and refill) (See notes 4 and 7) GO 1000

Drive Shaft Universal Joints (3 places) GAA 500

Rear Wheel Hub Level Plug (Check level) (See note 4) 50

INTERVAL ● LUBRICANT

50 GO Front Differential Fill and Level Plug (Check level) (See key)

1000 Front Differential Drain Plug (Drain and refill)

500 Transfer Case Drain Plug (Drain and refill) (See note 3)

10 OE/HDO Transfer Case Fill and Level Plug (Check level) (See note 3)

500 GAA Propeller Shaft Splines and Bearings (Sprangly with hand gun)

1000 Rear Differential Drain Plug (Drain and refill)

50 GO Rear Differential Fill and Level Plug (See key) (Check level)

SIDE PANEL

-KEY-

LUBRICANTS	CAPACITY	EXPECTED TEMPERATURES			INTERVALS
		Above +32° F	+40° F to -10° F	0° F to -65° F	
OE/HDO-LUBRICATING OIL, Engine					Intervals given are in hours of normal operation
Transfer Case	24 qt	OE HDO 30	OE HDO 10	OE A	
Oil Can Points					
OE A-OIL, Engine Sub-zero					
GO-LUBRICATING OIL-Gear		GO 90	GO 90	GOS	
Front & Rear Wheel Hub	4 qt ea				
Front & Rear Differential	10 qt ea				FOLD
FOLD					
Steering Gear Housing	1 qt	GO 90	GO 90	GOS	
GOS-LUBRICATING OIL, Gear, Sub-zero					
GAA-GREASE, Automotive and Artillery		ALL TEMPERATURES			

NOTES

- FOR OPERATION OF EQUIPMENT IN PROTRACTED COLD TEMPERATURES BELOW -10° F.** Remove lubricants prescribed in the key for temperatures above -10° F. Relubricate with lubricants specified in the key for temperatures below -10° F.
- OIL CAN POINTS.** Every 50 hours lubricate all control linkage, pins and clevises, and all exposed adjusting threads with OE/HDO.
- TORQUE CONVERTER, TRANSMISSION AND TRANSFER CASE** are interconnected and lubricated from the transfer case oil supply. Every 500 hours, drain and refill, after draining remove oil screen (located on the front side of the oil galley) clean and install. Fill transfer case to full mark, start engine and allow oil to warm, with oil at operating temperature, transmission in neutral and engine at fast idle (1000 rpm) fill sump to full mark on gage. **CAUTION** Oil level must be checked with engine running. Oil will drain from torque converter back into the sump when engine is not running. Removal of filler plug will allow the oil to overflow.
- WHEEL HUBS.** To drain, turn wheel until fill and drain plug is at bottom center. Fill housing by turning wheel until fill and drain plug is in an upward position. Check level with arrow pointing straight down. Fill until lubricant extrudes from level plug. (Lower plug opening)
- SHIFTER SPROCKETS AND SLIDES.** Every 10 hours, more often as needed under severe conditions, fording operations and extreme sandy conditions, lubricate with GAA.
- CONSTANT VELOCITY JOINT.** After operation in sea water remove a bolt (only 1 of 4) from bottom bearing cap, drain off water, inject GAA thru top fitting to remove contaminated lube. Replace bearing cap bolt. Relubricate.
- FRONT AND REAR WHEEL HUB FILL AND DRAIN PLUGS.** After operation in sea water, check lubricant for discoloration. If lube is milky color, drain and refill.
- DIFFERENTIAL LOCK CONTROL.** Check level every 100 hours. Oil should be within 3/4 inch of the top of valve. Drain only when repaired. Bleed lines at the lock-out mechanism on the differential. Use HBA Brake fluid (MIL-H-13910) on S/N E1468 and up. Use oil OE/HDO-10 (MIL-L-2104C) for S/N below S/NE1468.
- LUBRICANTS.** The following is a list of lubricants with the Military Symbols and the applicable specification numbers.

OE/HDO MIL-L-2104C	GAA MIL-G-10924
OE A PG PD*1	GOS MIL-L-10324
GO MIL-L-2105	
- DISCONNECT LINKAGE LUBRICATION POINT.** Fitting is located at upper and lower end of linkage.

Copy of this Lubrication Order will remain with the equipment at all times, instructions contained herein are mandatory.

BY ORDER OF THE SECRETARY OF THE ARMY.

OFFICIAL

10-10-3930-242-12-1 DISTRIBUTION: To be distributed in accordance with DA Form 12-25A (copy to block No. 197) Operator's Maintenance requirements for Trucks, Fork Lift, Rough Terrain

Figure 3-1. LO 10-3930-242-12-1/2 (Sheet 2 of 4)

TA157258

**LUBRICATION
ORDER**

LO10-3930-242-12-2

(Supersedes LO10-3930-242-12-2, did 1 MARCH 73)

**TRUCK, LIFT, FORK, DIESEL ENGINE, PNEUMATIC TIRED WHEELS,
ROUGH TERRAIN, 6000 LB CAPACITY, 24 INCH LOAD CENTER,
(ANTHONY MODEL MLT-6) (ARMY MODEL MHE 200)
(CHRYSLER MODEL MLT-6CH) (ARMY MODEL MHE
202) (ATHEY MODEL ARTFT-6) (ARMY MODEL
MHE 222) W/DETROIT DIESEL ENGINE
MODEL 5043-7000**

Reference: LO10-3930-242-12-1 and FEDERAL SUPPLY CATALOG C9100-IL

Intervals are based on normal hours of operation. Adjust to compensate for abnormal operation and severe conditions. During inactive periods, sufficient lubrication must be performed for adequate preservation.

Clean parts with SOLVENT, dry-cleaning, Type II (SD-2). Dry before lubricating.

Clean fittings before lubricating.

Lubricate points indicated by dotted arrow shafts on both sides of equipment.

Relubricate after washing or fording.

Drain crankcase when hot. Fill and check level.

A dotted circle indicate a drain below.

FOLD

FOLD

LUBRICANT ● INTERVAL		INTERVAL ● LUBRICANT
Side Shifter Chain (Clean and coat) (See note 5)	CW 10	10 GAA Slave Cylinder (3 places)
Tilt Cylinder	GAA 10	10 GAA Oscillation Cylinder (Upper and lower)
Slides (Clean and coat)	GG-2 50	10 GAA Tie Rod Ends
Control Levers and Linkage (Oil can points)	OE/HDO 50	10 GAA Lift Cylinder Rod End
Steering Cross-Shaft	GAA 50	10 GAA Lift Cylinder Trunnion Mount
Steering Linkage (5 places) (Remove cover for access)	GAA 50	50 GAA Control Lever Shaft
Control Levers and Linkage (Oil can points)	OE/HDO 50	50 GAA Control Levers and Linkage
Brake Pedal Shaft	GAA 50	500 Transfer Case Oil Fil- ter (See note 4)
Hydraulic Oil Tank Drain (Drain and refill)	500	10 GAA Tie Rod Ends
Hydraulic Oil Tank Fill, and Level Gage (Check level) (See key)	OE/HDO 10	
Hydraulic Tank Oil Filter (Remove, clean, and install) (See note 6)	500	

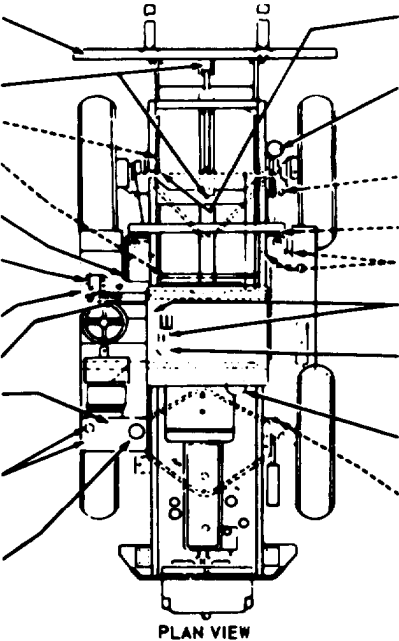

TA157259

Figure 3-1. LO 10-3930-242-12-1/2 (Sheet 3 of 4)

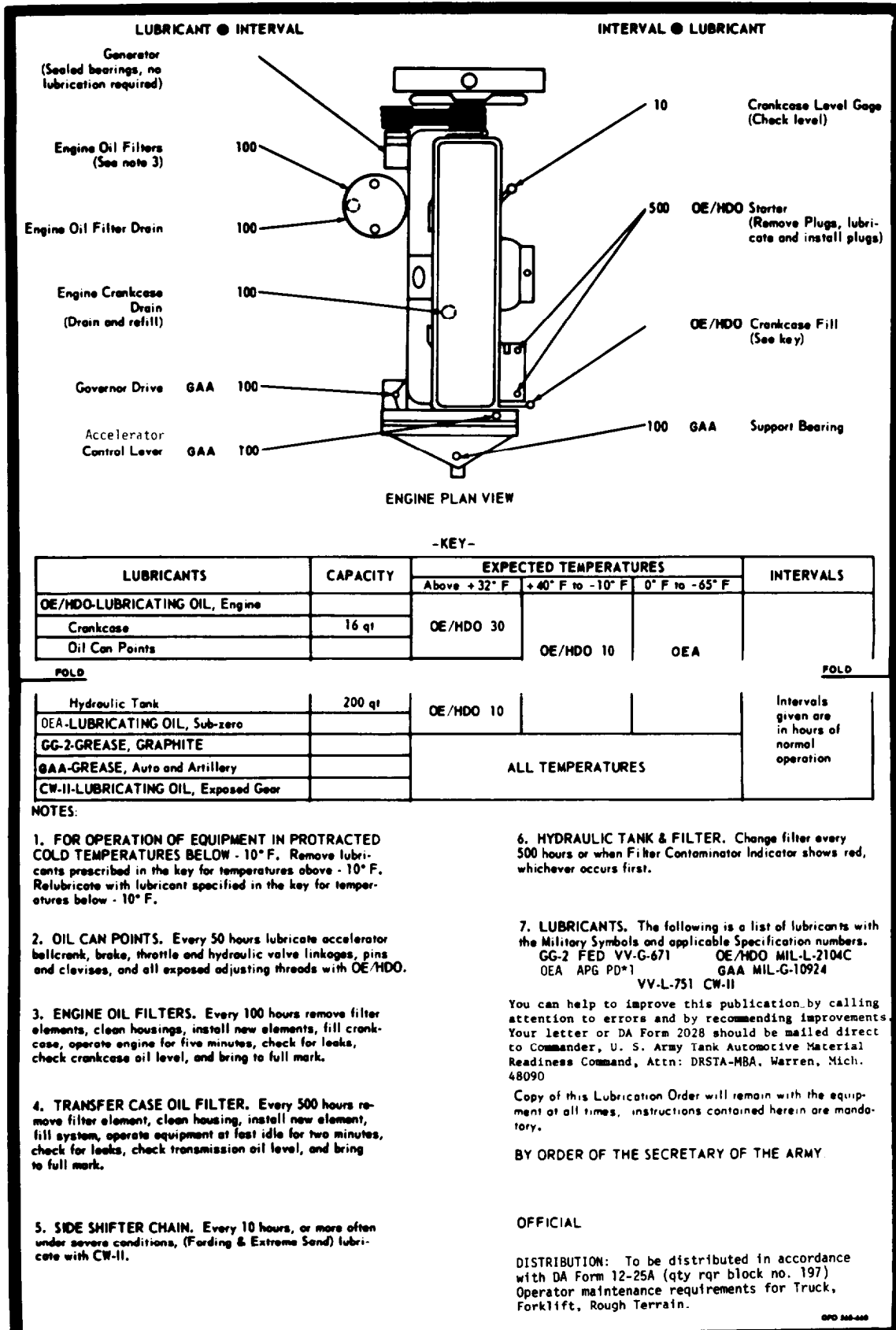

-KEY-

LUBRICANTS	CAPACITY	EXPECTED TEMPERATURES			INTERVALS
		Above +32° F	+40° F to -10° F	0° F to -65° F	
OE/HDO-LUBRICATING OIL, Engine	16 qt	OE/HDO 30			
Crankcase			OE/HDO 10	OEA	
Oil Can Points					

FOLD		FOLD			Intervals given are in hours of normal operation
Hydraulic Tank	200 qt	OE/HDO 10			
DEA-LUBRICATING OIL, Sub-zero		ALL TEMPERATURES			
GG-2-GREASE, GRAPHITE					
GAA-GREASE, Auto and Artillery					
CW-II-LUBRICATING OIL, Exposed Gear					

NOTES:

1. FOR OPERATION OF EQUIPMENT IN PROTRACTED COLD TEMPERATURES BELOW -10° F. Remove lubricants prescribed in the key for temperatures above -10° F. Relubricate with lubricant specified in the key for temperatures below -10° F.

2. OIL CAN POINTS. Every 50 hours lubricate accelerator ballcrank, brake, throttle and hydraulic valve linkages, pins and clevises, and all exposed adjusting threads with OE/HDO.

3. ENGINE OIL FILTERS. Every 100 hours remove filter elements, clean housings, install new elements, fill crankcase, operate engine for five minutes, check for leaks, check crankcase oil level, and bring to full mark.

4. TRANSFER CASE OIL FILTER. Every 500 hours remove filter element, clean housing, install new element, fill system, operate equipment at fast idle for two minutes, check for leaks, check transmission oil level, and bring to full mark.

5. SIDE SHIFTER CHAIN. Every 10 hours, or more often under severe conditions, (Fording & Extreme Sand) lubricate with CW-II.

6. HYDRAULIC TANK & FILTER. Change filter every 500 hours or when Filter Contaminator Indicator shows red, whichever occurs first.

7. LUBRICANTS. The following is a list of lubricants with the Military Symbols and applicable Specification numbers.
 GG-2 FED VV-G-671 OE/HDO MIL-L-2104C
 OEA APG PD*1 GAA MIL-G-10924
 VV-L-751 CW-II

You can help to improve this publication by calling attention to errors and by recommending improvements. Your letter or DA Form 2028 should be mailed direct to Commander, U. S. Army Tank Automotive Material Readiness Command, Attn: DRSTA-MBA, Warren, Mich. 48090

Copy of this Lubrication Order will remain with the equipment at all times. Instructions contained herein are mandatory.

BY ORDER OF THE SECRETARY OF THE ARMY

OFFICIAL

DISTRIBUTION: To be distributed in accordance with DA Form 12-25A (qty rqr block no. 197) Operator maintenance requirements for Truck, Forklift, Rough Terrain.

GPO 242-440

Figure 3-1. LO 10-3930-242-12-1/2 (Sheet 4 of 4)

SECTION II. OPERATOR/CREW PREVENTIVE MAINTENANCE CHECKS AND SERVICES (PMCS)

3-3. Maintenance Forms and Records

Every mission begins and ends with the paperwork. There isn't much of it, but you have to keep it up. The forms and records you fill out have several uses. They are a permanent record of the services, repairs, and modifications made on your equipment. They are reports to organizational maintenance and to your commander. They are also a checklist for you when you want to know what is wrong with the equipment after its last use, and whether those faults have been fixed. For the information you need on forms and records, see DA Pam 738-750.

3-4. General

Your Preventive Maintenance Checks and Services Table lists the inspections and care of your equipment required to keep it in good operating condition.

3-4.1. Operator/Crew Preventive Maintenance Checks and Services

a. The number column of your PMCS is the source for the number used on the TM Number Column on DA Form 2404.

b. The interval column of your PMCS Table tells you when to do a certain check or service.

(1) *Before you operate.* Perform your before (B) PMCS. Always keep in mind the WARNINGS and CAUTIONS.

(2) *While you operate.* Perform your during (D) PMCS. Always keep in mind the WARNINGS and CAUTIONS.

(3) *After you operate.* Be sure to perform your after (A) PMCS. Always keep in mind the WARNINGS and CAUTIONS.

(4) *Once a week.* Perform your weekly (W) PMCS. Always keep in mind the WARNINGS and CAUTIONS.

c. The procedure column of your PMCS Table tells you how to do the required checks and services. Carefully follow these instructions. If you do not have the tools, or if the procedure tells you to, have organizational maintenance do the work.

d. If your equipment does not perform as required, refer to the troubleshooting section in this manual for possible problems. Report any malfunctions or failures on the proper DA Form 2404 or refer to DA Pam 783-750.

NOTE

The terms ready/available and mission capable refer to the same status: Equipment is on hand and is able to perform its combat missions (see DA Pam 738-750).

e. Equipment is not ready/available if: column. This column tells you when and why your equipment cannot be used.

f. Always do your PMCS in the same order so it gets to be a habit. Once you've had some practice, you will spot anything wrong in a hurry.

g. When you do your PMCS, take along a rag or two.

h. While performing PMCS, observe all WARNINGS and CAUTIONS preceding those operations which could endanger your safety or result in damage to the equipment.

WARNING

Dry cleaning solvent, P-D-680, is toxic and flammable. Wear protective goggles and gloves and use only in a well-ventilated area. Avoid allowing solvent to contact skin, eyes, and clothes, and don't breathe vapors. Do not use near open flame or excessive heat. If you become dizzy while using cleaning solvent, get fresh air immediately and get medical aid. If solvent comes in contact with skin or clothing, wash with water. If solvent gets in your eyes, flush eyes with water and get medical aid immediately. Flash point of solvent is 100°-138°F (38°-59°C).

(1) *Keep it clean.* Dirt, grease, oil and debris only get in the way and may cover up a serious problem. Clean as you work and as needed. Use dry cleaning solvent (P-D-680) to clean metal surfaces. Use soap and water when you clean rubber or plastic material.

(2) *Bolts, nuts, and screws.* Check that they are not loose, missing, bent, or broken. You can't try them all with a tool, of course, but look for chipped paint, bare metal, or rust around bolt heads. Tighten any bolt, nut, or screw that you find loose.

(3) *Welds.* Look for loose or chipped paint, rust or gaps where parts are welded together. If you find a bad weld, report it to organizational maintenance.

(4) *Electric wires and connectors.* Look for cracked or broken insulation, bare wires, and loose

or broken connectors. Report damaged or loose wiring to organizational maintenance.

(5) *Hoses and fluid lines.* Look for wear, damage, and leaks. Make sure clamps and fittings are tight. Wet spots show leaks, but a stain around a fitting or connector can also mean a leak. If leakage comes from a loose fitting or connector, tighten the fitting or connector. If something is broken or worn out, report it to organizational maintenance.

(6) *Fluid level.* Vehicle must be on level ground in order to get correct fluid level measurement.

i. It is necessary for you to know how fluid leaks affect the status of your equipment. The following are definitions of the types/classes of leakage you need to know to be able to determine the status of your equipment. Learn and be familiar with them, and REMEMBER —when in doubt, notify your supervisor.

Leakage Definitions for Operator/Crew PMCS

- Class I Seepage of fluid (as indicated by wetness or discoloration) not great enough to form drops.
- Class II Leakage of fluid great enough to form drops, but not enough to cause drops to drip from the item being checked/inspected.
- Class III Leakage of fluid great enough to form drops that fall from the item being checked/inspected.

CAUTION

Equipment operation is allowable with minor leakages (Class I or II). Of course, consideration must be given to the fluid capacity in the item/system being checked/inspected. When operating with Class I or II leaks, continue to check fluid levels as required on your PMCS. Class III leaks should be reported to your supervisor or to organizational maintenance.

Table 3-1. Operator/Crew Preventive Maintenance Checks and Services

NOTE: Within designated Interval, these checks are to be performed in the order listed.

Item No.	Interval				Item To Be Inspected Procedure: Check for and have repaired, filled, or adjusted as needed.	Equipment is not Ready/ Available If:
	B	D	A	W		
1					<p>IMPORTANT - PERFORM WEEKLY (W) AS WELL AS BEFORE (B) OPERATIONS PMCS IF:</p> <p>a. You are the assigned operator and have not operated the vehicle since the last weekly PMCS.</p> <p>b. You are operating the vehicle for the first time.</p> <p>EXTERIOR OF VEHICLE</p> <p>a. Check for fuel, engine oil, coolant and hydraulic leaks or appearance of leakage.</p> <p>b. Visually check Roll Over Protective Structure (ROPS) for damage, bends, or cracks in weldment.</p> <p>c. Visually check forks, carriages, and side shifter frame for cracked, bent, or broken components or frame members.</p> <p>d. Visually check wiring harness and connections for frayed, broken, or burned wires.</p>	<p>Class III leaks are evident.</p> <p>Damage, bends, or cracks in weldment.</p> <p>Forks, carriage, or side shifter frame cracked, bent, or broken.</p> <p>Wiring is frayed, broken, or burned.</p>
	•					
	•					
	•					
2					<p>TIRES AND WHEELS</p> <p>a. Check tires for excessive wear, cuts, or abrasions, embedded foreign objects, and obviously low or flat condition. (Ref TM 9-2610-200-24)</p>	<p>Tires have cuts or abrasions which would result in tire failure. Tires are low, flat, or missing.</p>
	•					

Table 3-1. Operator/Crew Prventive Maintenance Checks and Services - Continued

NOTE: Within designated interval, these checks are to be performed in the order listed.

B – Before

D – During

A – After

W – Weekly

Item No.	Interval				Item To Be Inspected Procedure: Check for and have repaired, filled, or adjusted as needed.	Equipment is not Ready/ Available If:
	B	D	A	W		
3	•				b. Check wheels for loose or missing mounting bolts.	One or more bolts are loose or missing.
	•				FIRE EXTINGUISHER a. Check availability of fire extinguisher (if mission required). b. Check for proper pressure on dial (indicator in green area).	Fire extinguisher missing. Indicator in red area.
4	•				ENGINE OIL LEVEL Check level on dipstick. Maintain between "add" and "full."	
5	•				FUEL SYSTEM Drain water and contaminants from primary fuel filter.	
6	•				FAN AND DRIVE BELTS a. Check belts for worn, cracked or frayed condition.	Belts missing or damaged.
	•				b. Check for bent or damaged blades.	Blades bent or damaged.
7	•				HYDRAULIC RESERVOIR a. With mast lowered, all cylinders retracted, and engine "off," maintain reservoir oil level on dipstick between "add" and "full."	
	•				b. Visually check contamination indicator on top of hydraulic reservoir for "red" indication (para 4-76).	Indicator shows "red."
8	•				SEATBELT Check that seatbelt is securely mounted. Material is not cut or frayed, and that latch operates properly.	Belt missing, not securely mounted, material cut or frayed, or latch does not operate properly.
	•				<u>WARNING</u> If NBC exposure is suspected, all air filter media should be handled by personnel wearing protective equipment. Consult your unit NBC Officer or NBC NCO for appropriate handling or disposal procedures.	
9		•			AIR CLEANER Visually check contamination indicator.	Air cleaner indicator shows red.

Tabel 3-1. Operator/Crew Preventive Maintenance Checks and Services - Continued

NOTE: Within designated interval, these checks are to be performed in the order listed.

B — Before

D — During

A — After

W — Weekly

Item No.	Interval				Item To Be Inspected Procedure: Check for and have repaired, filled, or adjusted as needed.	Equipment is not Ready/ Available If:
	B	D	A	W		
10		•			<p>SERVICE BRAKES</p> <p>a. Turn master switch on. Low brake pressure warning buzzer comes on.</p> <p>b. Check low brake pressure warning buzzer by turning on the master switch. If buzzer does not sound, depress brake pedal 6-7 times to lower accumulator pressure. Warning buzzer should sound.</p>	<p>Warning buzzer does not sound.</p> <p>Warning buzzer sounds after 2 or 3 brake applications.</p> <p>Brakes fade, slip, or will not stop or hold vehicle.</p>
11					<p>INSTRUMENTS</p> <p>NOTE</p> <p>Run engine for three to five minutes and check the following indicators for proper reading.</p> <p>a. Coolant temperature 170°-220°F</p> <p>b. Converter temperature 100°-250°F</p> <p>c. Engine oil pressure 40-50 psi (Operation) low idle 8-15 psi</p> <p>d. Battery indicator green area</p> <p>e. Converter pressure 110-150 psi</p>	<p>Gages or instruments are missing, do not operate or do not indicate within normal ranges.</p>
12		•			<p>PARKING BRAKE</p> <p>Check that parking brake will prevent vehicle from moving with engine at low idle and transmission in forward gear, medium range.</p>	<p>Parking brake will not hold vehicle.</p>
13		•			<p>TRANSMISSION CONTROLS</p> <p>Check that transmission shift lever operates smoothly.</p>	<p>Lever sticks, binds, or does not operate smoothly.</p>
14		•			<p>STEERING</p> <p>Check that truck steers freely and easily.</p>	<p>Steering sticks or binds, or truck is hard to steer.</p>
15		•			<p>FORK OPERATION</p> <p>a. Check that lifting and lowering is smooth in operation.</p>	<p>Lifting or lowering is erratic or uncontrollable.</p>

Table 3-1. Operator/Crew Preventive Maintenance Checks and Services - Continued

NOTE: Within designated interval, these checks are to be performed in the order listed.

B — Before D — During A — After W — Weekly

Item No.	Interval				Item To Be Inspected Procedure: Check for and have repaired, filled, or adjusted as needed.	Equipment is not Ready/ Available If:
	B	D	A	W		
16		•			b. Check that fork tilt lever movement is smooth and immediate.	Operation is slow or erratic.
		•			c. Check extension cylinder lever for proper operation.	Nonoperational, but required for mission.
		•			d. Check that side shift operates.	Nonoperational, but required for mission.
		•			e. Check oscillator lever for smooth movement.	Movement is erratic or jerky.
17					HORN Check horn by pressing horn button.	Horn does not operate.
					ACCELERATOR Check that accelerator operates smoothly.	Pedal or linkage sticks or binds.
18					LIGHTS Check that head, tail, and floodlights are working.	Nonoperational, but required for night operation or where lights are required.
					TRANSMISSION At operating temperature (100°-250°F converter temperature) maintain transmission fluid level on dipstick between "add" and "full."	
20					BATTERIES WARNING Do not smoke or allow any flame or spark in the vicinity while checking the battery. The battery generates hydrogen, a highly explosive gas.	
				•	a. Visually check electrolyte level. If level of electrolyte is below the top of the battery plates, notify organizational maintenance.	
				•	b. Check battery and battery box for corrosion and obvious damage.	Battery missing, cracked, or will not crank engine.

Table 3-1. Operator/Crcw preventive Maintenance Checks and Semites-Conthwed

NOTE: Within designated Interval, these checks are to be performed in the order listed.

B - B e f o r e D - D u r i n g A - A f t e r W - W e e k l y

Item No.	Interval				Item To Be Inspected Procedure: Check for and have repaired, filled, or adjusted as needed.	Equipment is not Ready Available If:
	B	D	A	W		
21					<p>RADIATOR</p> <p>WARNING</p> <p>Pressurized cooling system. Remove cap slowly and only when engine is cool or painful burns could result.</p> <ul style="list-style-type: none"> Visually check coolant level and ensure that coolant is 1-1/2 to 2 inches below neck. 	Radiator obviously low or empty. Refer to instrument checks.
22					<p>FUEL SYSTEM</p> <p>CAUTION</p> <p>In freezing weather, drain water from primary falter after operation or damage to equipment could result.</p> <ul style="list-style-type: none"> Drain water and contaminants from primary falter. Frozen water in fuel system could cause damage to equipment. 	

Section III. TROUBLESHOOTING

3-5. General

a. This section contains troubleshooting information for locating and correcting most of the operating troubles which may develop in the rough terrain forklift truck. Each malfunction for an individual component, unit, or system is followed by a list of tests or inspections which will help you to determine corrective actions to take. You should perform the tests or inspections and corrective actions in the order listed.

b. This manual cannot list all malfunctions that may occur, nor all tests or inspections and corrective

actions. If a malfunction is not listed or is not corrected by listed corrective actions, notify your supervisor.

c. Table 3-2 lists the common malfunctions which you may find during the operation or maintenance of the rough terrain forklift truck or its components. You should perform the tests or inspections and the corrective actions in the order listed.

NOTE

Before you use this table, be sure you have performed all applicable operating checks.

Table 3-2. Operator/Crew Troubleshooting

Malfunction

Test or inspection

Corrective action

1. ENGINE FAILS TO START

Step 1. Check for hose, corroded or damaged battery cables and connection. Clean corroded cables. Tighten loose connections and report damaged cables to organizational maintenance.

Step 2. Check to be sure that engine shut-off is pushed down and that lever at the governor housing is in the start position. Adjust cable as necessary.

Step 3. Check to be sure the emergency stop is in operating position at the engine blower. Reset if required.

WARNING

If NBC exposure is suspected, all air filter media should be handled by personnel wearing protective equipment. Consult your unit NBC Officer or NBC NCO for appropriate handling or disposal procedures.

Step 4. Check for air cleaner intake restrictions. Correct as necessary.

Step 5. Check for empty fuel tank. Fill as required.

2. ENGINE OPERATES ERRATICALLY

Step 1. Check for clogged air cleaner. Have air cleaner serviced.

Step 2. Check for condensation and fuel contamination. Drain condensation from fuel filters before engine. Report evidence of fuel contamination to organizational maintenance.

Step 3. Notify supervisor and organizational/direct support maintenance to check governor gap.

3. ENGINE LACKS POWER

Step 1. Check for clogged air cleaner. Have air cleaner serviced.

Step 2. Check fuel filters for contamination. Drain condensation from fuel filters before starting engine. Report evidence of fuel contamination to organizational maintenance.

Step 3. Notify supervisor and organizational/direct support maintenance to check fuel rack and governor operation.

4. ENGINE OVERHEATS

Step 1. Check radiator for low level of coolant. Allow engine to cool and fill with coolant.

Step 2. Check fan belt for looseness. Report a hose or damaged fan belt to organizational maintenance.

Step 3. Check radiator for free airflow. Clean radiator fins if required.

5. ENGINE EXHAUST SMOKE EXCESSIVE

Step 1. Check for clogged air cleaner. Have air cleaner serviced.

6. ENGINE OIL CONSUMPTION EXCESSIVE

Step 1. Inspect engine compartment for oil leaks.

Do not continue operation if oil leak is likely to reduce engine off below a safe operating level. Report leaks to organisational maintenance.

7. STEERING ERRATIC

Step 1. Check for rear steering cross-shaft binding in tube.

Do not continue operation if the erratic steering constitutes a threat to personnel or may result in equipment damage. Report to organizational maintenance.

Step 2. Check for low level of hydraulic fluid.

Report low hydraulic fluid level to organizational maintenance.

8. BATTERY FAILS TO MAINTAIN CHARGE

Step 1. Check for low level of electrolyte.

Fill battery with distilled water.

Step 2. Visually inspect battery for damage such as loose terminal posts or warped internal plates. Report unserviceable batteries to organizational maintenance.

Section IV. OPERATOR/CREW MAINTENANCE PROCEDURES

3-6. Engine Air Cleaner Inspection

WARNING

If NBC exposure is suspected, all air filter media should be handled by personnel wearing protective equipment. Consult your unit NBC Officer or NBC NCO for appropriate handling or disposal procedures.

Loosen the clamp and remove the cup. Remove the element and inspect it for excessive accumulation of dirt. Remove the cup dust trap and inspect for

excessive accumulation of dust. Report to organizational maintenance for Servicing.

3-7. Ether Primer

Refer to figure 3-2 and service the ether primer.

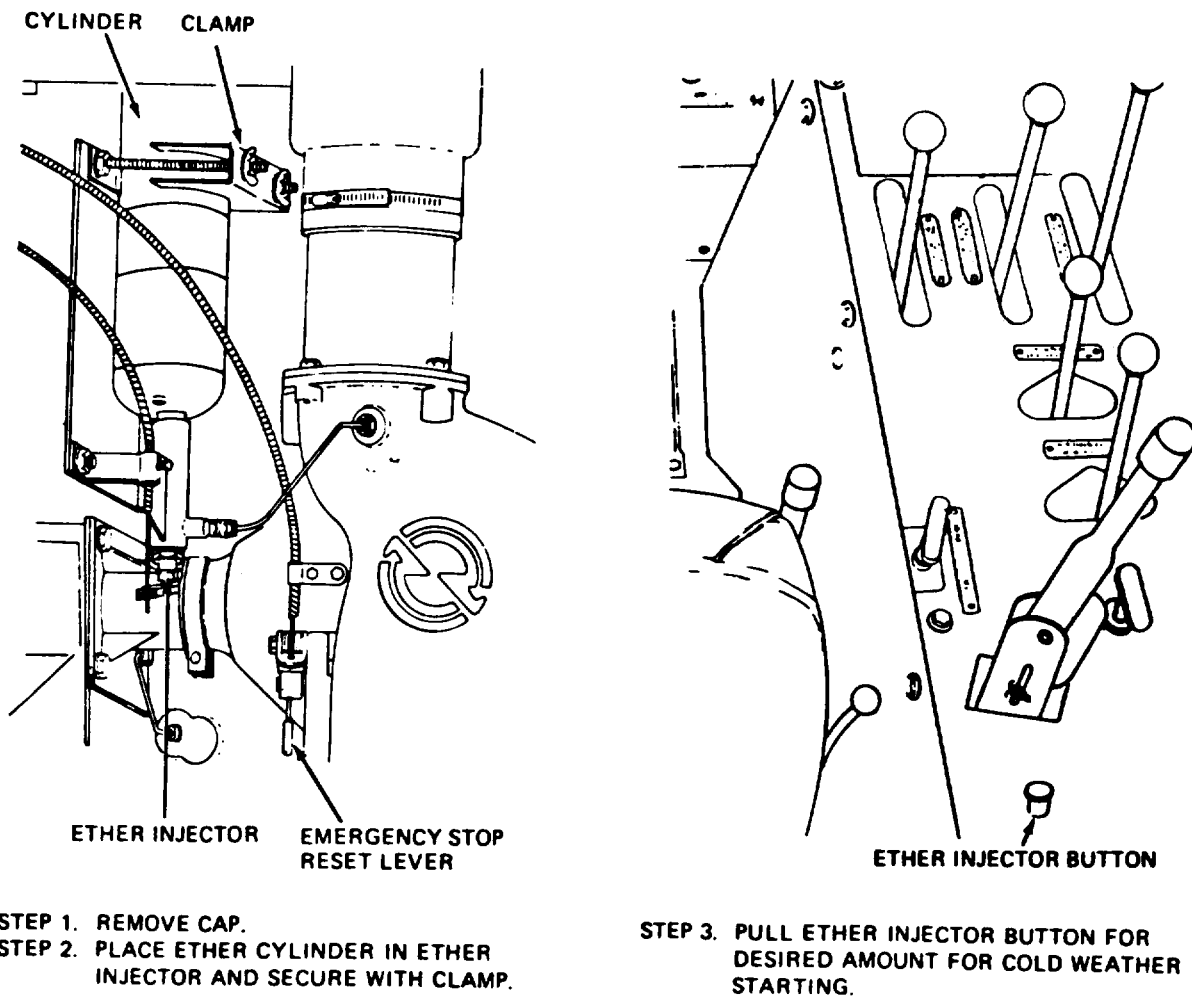

Figure 3-2. Ether primer servicing.

TA031836

3-8. Battery

Visually inspect batteries for damage, such as loose terminal posts or warped internal plates. Remove battery cell vent caps (fig. 3-3) and check the level of

electrolyte. The electrolyte should be one-half inch above the plates. Replace vent cap. Inspect cables and battery holddown hardware for corrosion.

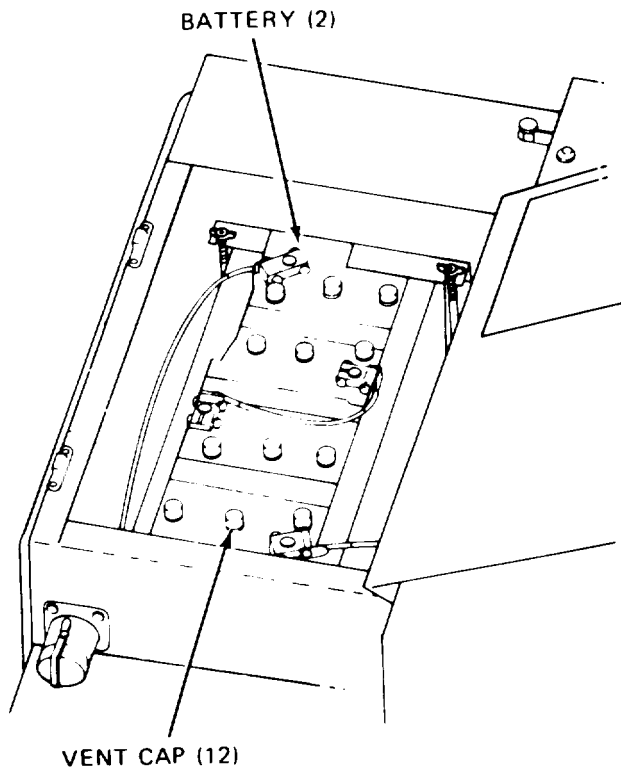

TA031838

Figure 3-3. Battery.

3-9. Fuel Tank

a. *Inspection.* Inspect the fuel tank for dents and leaks.

b. *Service.* Fill fuel tank with diesel fuel according to table 3-3.

Table 3-3. Fuel Use According to Temperature

Temperature range	Fuel
+20° F. and warmer	VVF-800 Type DF2
- 25° F. and warmer	VVF-800 Type DF1
- 25° F. and colder	VVF-800 Type DFA

3-10. Coolant Hoses and Fittings

Inspect hoses and fittings for cracks and damage. Inspect hoses for deterioration and cuts.

3-11. Exhaust Manifold and Flange

Inspect exhaust manifold and flange for cracks, nicks, and damaged parts. Refer to figure 3-4.

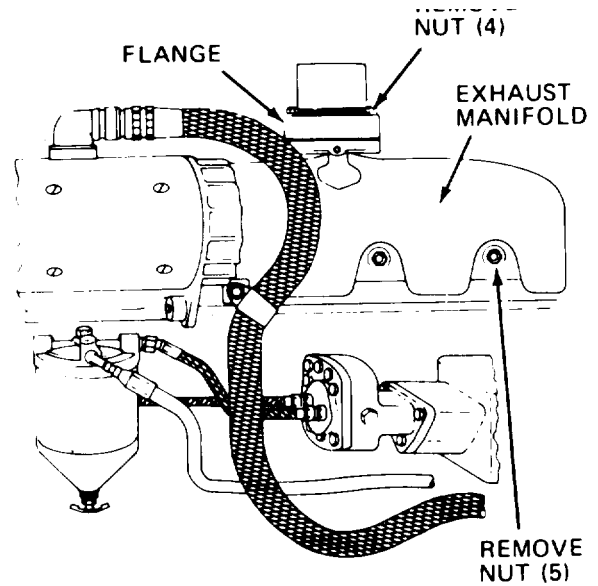

TA031839

Figure 3-4 Exhaust manifold and flange.

3-12. Muffler and Exhaust Pipe

Inspect muffler and exhaust pipe for cracks, dents, and rust.

3-13. Lights

a. *Inspection.* Visually inspect headlights, blackout lights, stop/taillights, and marker lights for operation.

b. *Adjustment.* Headlights and blackout lights may be adjusted to meet lighting requirements, as these requirements change with various jobs.

CHAPTER 4

ORGANIZATIONAL MAINTENANCE INSTRUCTIONS

Section I. SERVICE UPON RECEIPT OF MATERIAL

4-1. Inspecting New Equipment

- a. Assure that the required tools, repair parts, and other items troop installed or authorized are included with the equipment.
- b. Inspect the diesel engine and mounted components for damaged or missing items.
- c. Inspect wiring, fuel and oil lines, radiator hoses, fuel and hydraulic oil tanks, hydraulic system piping, gages, instruments, and lights for missing, loose, broken, or damaged parts.
- d. Inspect drain plugs, breathers, filter caps, and drain cocks for improper installation and damage.
- e. Inspect air and hydraulic hoses and lines and electrical leads for cuts, breaks, or signs of deterioration.
- f. Correct deficiencies falling within the limits of organizational maintenance.

4-2. Servicing Equipment

- a. Perform daily preventive maintenance as indicated in table 3-1.

WARNING

Avoid contact with electrolyte. If electrolyte comes in contact with eyes, flush thoroughly and immediately with cold water. Do not rub eyes. All parts of the

body touched by electrolyte should be washed with cold water immediately. For contact with fabrics, neutralize electrolyte using baking soda or household ammonia in addition to washing with cold water.

- b. Remove vent fill caps on the batteries and fill each cell with distilled water to a level one half inch above the tops of the plate separators.
- c. Replace vent caps.
- d. Apply a light coating of nonmetallic grease or petroleum jelly to the battery posts. Install battery cables. Tighten and cable terminals securely.
- e. Wipe the tops of the batteries and battery holddown hardware with a cloth moistened with baking soda or ammonia solution to remove any spilled acid. Wipe dry with a clean cloth.
- f. Insure that, all drain valves on the engine and radiator are closed. Fill the radiator with clean water to a level 1 ½ inches below the neck of the radiator.

NOTE

When operating in temperatures below freezing, use antifreeze in quantities indicated in table 2-1.

- g. Install and secure radiator cap.

Section II. MOVEMENT TO A NEW WORKSITE

CAUTION

Height of equipment should be considered when shipping. The installation of the roll over protective structure (ROPS) adds to the height which maybe damaged by low overpasses, bridges, and other structures.

4-3. Preparation For Movement

a. *Local Movement.* The forklift truck does not require special treatment for local relocation as it is capable of moving short distances under its own power.

b. *Shipment.*

(1) *Disassembly.* Remove side shift roller chain, cylinder, and forks. Refer to paragraph 4-75.

(2) *Roll Over Protective Structure (ROPS).*

(a) Depending on the mode of shipment, height requirements, route, etc., it maybe necessary to remove ROPS prior to shipping.

(b) Refer to paragraph 4-68 and remove ROPS.

(3) *Mode of Shipment.* Either railroad flat car or low-boy trailer can be used to transport the forklift truck over long distances. Secure the forklift truck to the trailer or flat car and cover as required.

4-4. Assembly After Movement

a. Refer to paragraph 4-74 and install side shift roller chain, cylinder, and forks.

b. If ROPS was removed prior to shipping, refer to paragraph 4-68 and install ROPS after movement.

Section III. REPAIR PARTS, SPECIAL TOOLS AND EQUIPMENT

4-5. Tools and Equipment

There are no special tools and equipment authorized for maintenance of this equipment.

4-6 Maintenance Repair Parts.

Repair parts and equipment are listed and illustrated in TM 10-3930-242-20P.

Section IV. ORGANIZATIONAL PREVENTIVE MAINTENANCE
CHECKS AND SERVICES (PMCS)**4-7. General**

To make sure that your vehicle is ready for operation at all times, inspect it systematically so you can discover any defects and have them corrected before they result in serious damage or failure. The table on the next few pages contains your organizational PMCS. The item numbers indicate the sequence of minimum inspection requirements. If you're operating the vehicle and notice something wrong which could damage the equipment if you continue operation, stop operation immediately.

Record all deficiencies and shortcomings, along with the corrective action taken, on DA Form 2404. The Item Number Column is the source for the numbers used on the TM Number Column on DA Form 2404.

4-8. Organizational Preventive Maintenance Checks and Services

a. The item numbers of the table indicate the sequence of the PMCS. Perform at the intervals shown below.

(1) Do your (Q) PREVENTIVE MAINTENANCE quarterly (every three months).

(2) Do your (A) PREVENTIVE MAINTENANCE annually (once every year).

b. If something doesn't work, troubleshoot it according to the instructions in this manual or notify your supervisor.

c. Always do your preventive maintenance in the same order so it gets to be a habit. Once you've had some practice, you will spot anything wrong in a hurry.

d. If anything looks wrong and you can't fix it, write it down on your DA Form 2404. If you find something seriously wrong, report it to direct support as soon as possible.

Dry cleaning solvent, P-D-680, is toxic and flammable. Wear protective goggles and gloves, and use only in a well-ventilated area. Avoid allowing solvent to contact skin, eyes, and clothes, and don't breathe vapors. Do not use near open flame or excessive heat. If you become dizzy while using cleaning solvent, get fresh air immediately and get medical aid. If solvent comes in contact with skin or clothing, wash with water. If solvent gets in your eyes, flush eyes with water and get medical aid immediately. Flash point of solvent is 100°-138°F (38°-59°C).

(1) *Keep it clean.* Dirt, grease, oil, and debris only get in the way and may cover up a serious problem. Clean as you work and as needed. Use dry cleaning solvent (P-D-680) to clean metal surfaces. Use soap and water when you clean rubber or plastic material.

(2) *Bolts, nuts, and screws.* Check that they are not loose, missing, bent, or broken. You can't try them all with a tool, of course, but look for chipped paint, bare metal, or rust around bolt heads. Tighten any bolt, nut, or screw that you find loose.

(3) *Welds.* Look for loose or chipped paint, rust, or gaps where parts are welded together. If you find a bad weld, report it to direct support.

(4) *Electric wires and connectors.* Look for cracked or broken insulation, bare wires, and loose or broken connectors. Tighten loose connections and make sure the wires are in good condition.

(5) *Hoses and fluid lines.* Look for wear, damage, and leaks. Make sure clamps and fittings are tight. Wet spots show leaks, but a stain around a fitting or connector can also mean a leak. If leakage comes from a loose fitting or connector, tighten the fitting or connector. If something is broken or worn out, either correct it or report it to direct support.

e. It is necessary for you to know how fluid leaks affect the status of your equipment. The following are definitions of the types/classes of leakage you need to know to be able to determine the status of your equipment. Learn and be familiar with them, and REMEMBER — when in doubt, notify your supervisor.

- Leakage Definitions for Operator/Crew PMCS*
- Class I Seepage of fluid (as indicated by wetness or discoloration) not great enough to form drops.
 - Class II Leakage of fluid great enough to form drops, but not enough to cause drops to drip from the item being checked/inspected.
 - Class III Leakage of fluid great enough to form drops that fall from the item being checked/inspected.

Table 4-1. Organizational Preventive Maintenance Checks and Services

Q - Quarterly

A-Annually

Item No.	Interval		Item To Be Inspected Procedure: Check for and have repaired, filled, or adjusted as needed.
	Q	A	
1			<p style="text-align: center;">NOTE</p> <p>Perform operator/crew PMCS before or in conjunction with organizational PMCS if:</p> <ul style="list-style-type: none"> a. <i>There is a delay between the daily operation of the equipment and the organizational PMCS.</i> b. Regular operator is not assisting/participating. <p>BATTERIES</p> <p style="text-align: center;">WARNING</p> <p>Do not smoke or allow any flame or spark in the vicinity while checking or filling battery. The battery generates hydrogen, a highly explosive gas.</p> <p style="text-align: center;">CAUTION</p> <p>In cold weather operations, charge battery immediately after adding water to combine the water with battery electrolyte to prevent freezing. Be careful not to overfill when servicing batteries.</p> <ul style="list-style-type: none"> ● a. Test battery to determine cell condition. (Ref TM 9-6140-200-14) ● b. Clean battery top and terminals. Ensure that all connections are tight. (Ref TM 9-6140-200-14)
			<p>TIRES AND WHEELS</p> <p style="text-align: center;">WARNING</p> <p>Ensure that lockring is properly seated before inflating tire. Serious injury or death to personnel may result should lockring snap out of seat.</p> <ul style="list-style-type: none"> ● a. Check tire air pressure (45 psi front, 35 psi rear). ● b. Check tires for cuts, wear, and deterioration. (Ref TM 9-2610-200-24) ● c. Check locking rim, wheel flanges, wheel, and nuts for cracks, breaks, and dents. Replace all defective parts.
3			<p>BELTS</p> <ul style="list-style-type: none"> ● Check for excessive wear, damage, and proper tension (1/2 inch to 3/4 inch deflection with about 10 lbs applied force midway between the pulleys) (para 4-28).

Table 4-1. Organizational Preventive Maintenance Checks and Services-Continued

Q - Quarterly

A-Annually

Item No.	Interval		Item To Be Inspected Procedure: Check for and have repaired, filled, or adjusted as needed.
	Q	A	
4			<p>AIR CLEANER</p> <p style="text-align: center;">WARNING</p> <p>Low pressure air used for cleaning purposes will not exceed 30 psi. Effective chip guarding and personnel protective equipment (goggles/shield, gloves, etc.) will be used.</p> <p>If NBC exposure is suspected, all air filter media will be handled by personnel wearing full NBC protective equipment.</p> <ul style="list-style-type: none"> ● Clean air cleaner filter with low pressure air by blowing from the inside out (para 4-20). Reset contamination indicator.
5			<p>FUEL SYSTEM</p> <ul style="list-style-type: none"> ● a. Clean primary fuel filter (para 4-22). ● b. Replace secondary fuel filter (para 4-22).
6			<p>CRANKCASE BREATHER</p> <ul style="list-style-type: none"> ● Clean crankcase breather (para 4-13).
7			<p>SERVICE BRAKES</p> <ul style="list-style-type: none"> ● Check for lining wear (para 4-59).
8			<p>HOSES, LINES, AND FITTINGS</p> <ul style="list-style-type: none"> ● Inspect all hoses, lines, and fittings for damage or leaks (para 4-77).
9			<p>PARKING BRAKE</p> <ul style="list-style-type: none"> ● Check parking brake for proper adjustment (para 4-60 and 4-61).
10			<p>FRAME AND CARRIAGE</p> <ul style="list-style-type: none"> ● Check frame, forks, and carriages for damage, cracks, or bends.
11			<p>RADIATOR</p> <p style="text-align: center;">WARNING</p> <p>Pressurized cooling system. Remove cap slowly and only when radiator is cool or serious burns could result.</p> <ul style="list-style-type: none"> ● Check coolant condition in accordance with TB 750-651 and inspect cooling system for excessive rust or corrosion. Drain, clean, and refill the cooling system if required (para 4-25 and 4-26).

Section V. TROUBLESHOOTING

4-9. General

This section contains troubleshooting information for locating and correcting most of the malfunctions which may occur in the 6,000 pound rough terrain forklift truck, Army Models MHE 200, MHE 202, and MHE 222. Each malfunction for an individual component, unit, or system is followed by a list of tests or inspections. The tests and inspections will help to determine probable causes and corrective

actions to be taken. Perform the tests/inspections and corrective actions in the order listed.

4-10. Limitation

This manual cannot list all malfunctions that may occur, nor all tests or inspections and corrective actions. Notify your supervisor when malfunctions occur that are not covered in troubleshooting table 4-2.

Table 4-2. Organizational Troubleshooting

Malfunction	Test or inspection	Corrective action
1. ENGINE WILL NOT CRANK		
	Step 1. Inspect battery connections for poor contact. Clean contact surfaces of battery connections and reinstall serviceable cables. Replace cables that are damaged beyond repair.	
	Step 2. Using a hydrometer, test the specific gravity of the electrolyte. A reading of 1.220 or lower indicates that the battery is less than half charged. If electrolyte is too low to test, add distilled water and charge batteries for one hour before checking hydrometer readings. If battery does not accept charge, replace (para 4-34).	
	Step 3. Inspect starter for defective wiring. Replace starter (para 4-37).	
WARNING		
If NBC exposure is suspected, all air filter media should be handled by personnel wearing protective equipment. Consult your unit NBC officer or NBC NCO for appropriate handling or disposal procedures.		
2. ENGINE CRANKS, BUT FAILS TO START		
	Step 1. Check to be sure engine shut-off is pushed down and that cable is actuating the governor control.	
	Step 2. Check to be sure emergency shut-off is in start position.	
	Step 3. Check the fuel tank for fuel and fuel filters for contamination. Refuel and/or replace filters as necessary (para 4-22).	
	Step 4. Inspect air cleaner for obstruction. Clean if required (para 4-20).	
3. ENGINE OPERATES ERRATICALLY		
	Step 1. Check to be sure fuel filters are not obstructing flow. Clean if required (para 4-22).	
	Step 2. Check air cleaner for restriction. Clean if required (para 4-20).	
	Step 3. Notify supervisor and direct support to check governor and fuel rack.	
4. ENGINE LACKS POWER		
	Step 1. Inspect throttle linkage for damage, excessive wear, and limited movement. Adjust serviceable linkage. Replace damaged or excessively worn linkage.	
	Step 2. Inspect air cleaner for damage or obstruction. Replace damaged air cleaner or faulty air cleaner hoses (para 4-20).	
	Step 3. Notify supervisor and direct support maintenance to check governor and fuel rack.	
5. ENGINE OVERHEATS		
	Step 1. Check radiator fins for free air flow. Clean if required.	
	Step 2. Inspect for loose, damaged, or broken fan belts. Adjust loose fan belts. Replace unserviceable belts (para 4-28).	
	Step 3. Inspect for poor coolant circulation. Replace faulty hoses, clamps (para 4-26) and thermostats (para 4-24). Check water pump and replace if faulty (para 4-25).	
6. EXCESSIVE LUBRICATING OIL CONSUMPTION		
	Step 1. Inspect engine compartment for evidence of oil leakage. Replace defective or worn hoses, tubing, fittings, and gaskets.	
7. TRANSMISSION AND TORQUE CONVERTER OVERHEATS		
	Step 1. Inspect for low transmission oil level. Service transmission IAW LO 10-3930-242-12-1.	
	Step 2. Check for loss of oil due to defective hose assemblies. Replace hose assemblies (para 4-77).	

Table 4-2. Organizational Troubleshooting-Continued

Malfunction	Test or inspection	Corrective action
		Step 3. Inspect for clogged or damaged filter. Clean or replace filter as necessary (para 4-54). Step 4. Check gear range being used by operator. May have to use lower gear range for specific operating condition.
8. CONVERTER STALL SPEED LOW		Step 1. Inspect throttle linkage for proper adjustment. Adjust linkage for full governor travel. Step 2. Notify supervisor and direct support to check governor and fuel rack.
9. STEERING ERRATIC		Step 1. Inspect steering cross-shaft for binding in the tube. Lubricate cross-shaft and all steering linkage IAW LO 10-3930-242-12-2.
10. BATTERIES FAIL TO MAINTAIN CHARGE		Step 1. Inspt battery for shorted plates or loose terminal posts. Replace shorted <i>or</i> unserviceable batteries (para 4-34).
11. BRAKES WILL NOT APPLY		Step 1. Inspect for hydraulic leaks in the brake system. Replace defective hoses, lines, fittings, and seal (para 4-77). Step 2. Inspect for air in hydraulic system. Bleed hydraulic brake system (para 4-59b).
12. BRAKES DRAG, RUN HOT, OR DO NOT RELEASE PROPERLY		Step 1. Inspect for air in hydraulic actuating system. Bleed service brakes (para 4-59b). Step 2. Inspect for clogged or restricted hydraulic tank filter (para 4-76). Replace clogged or damaged filter IAW LO 10-3930-242-12-2.
13. LOW HYDRAULIC SYSTEM PRESSURE		Step 1. Check for clogged hydraulic filter (para 4-76). Replace if required IAW LO 10-3930-242-12-2. Step 2. Inspect for leaks at cylinder gland packing. Tighten packing nuts. If leakage continues, report to direct support maintenance.

Section VI. MAINTENANCE OF LUBRICATION SYSTEM

WARNING

Drycleaning solvent, P-D-680, used to clean parts is potentially dangerous to personnel and property. Do not use near open flame or excessive heat. Flash point of solvent is 138° F.

4-11. General

This section contains information for organizational maintenance of the lubrication system. Maintenance includes oil filter, crankcase breather, and dipstick.

4-12. Oil Filter

a. Removal. Refer to figure 4-1 and remove the oil filter.

b. Cleaning and Inspection.

(1) Refer to figure 4-2 and service the oil filter. Remove center stud and disassemble filter as shown.

(2) Make sure the gasket surfaces are clean. Clean with drycleaning solvent (item 1, App F) and dry thoroughly.

(3) Inspect flange and block for nicks and cracks. Remove small nicks with emery cloth.

c. Installation. Use a new gasket. Refer to figure 4-1 and install oil filter.

CAUTION

Check for oil leaks while engine is running. Oil leaks could cause serious damage to the engine.

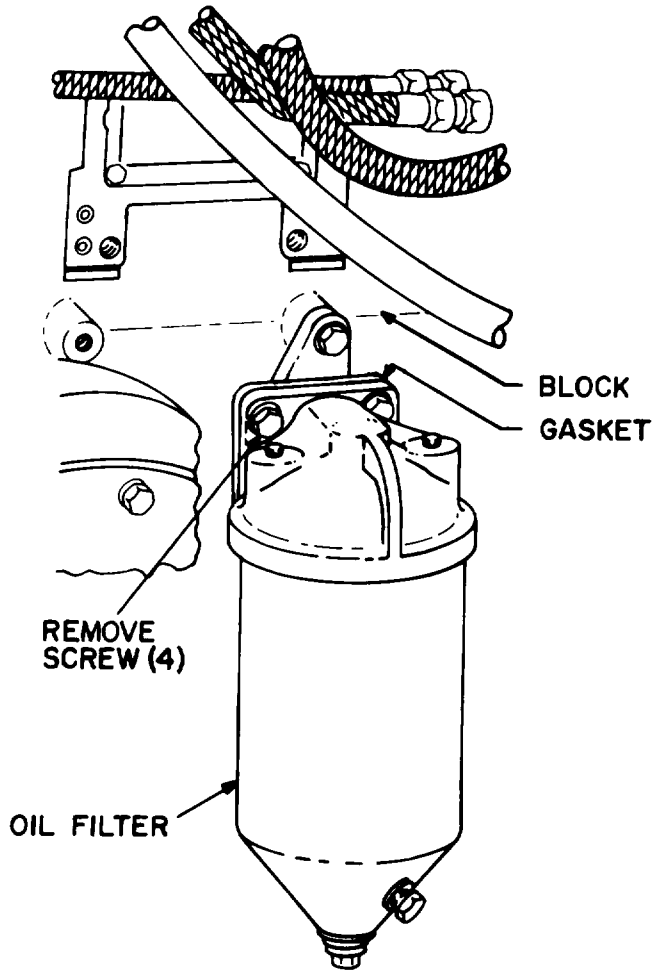

TA072393

Figure 4-1. Oil filter, removal and installation.

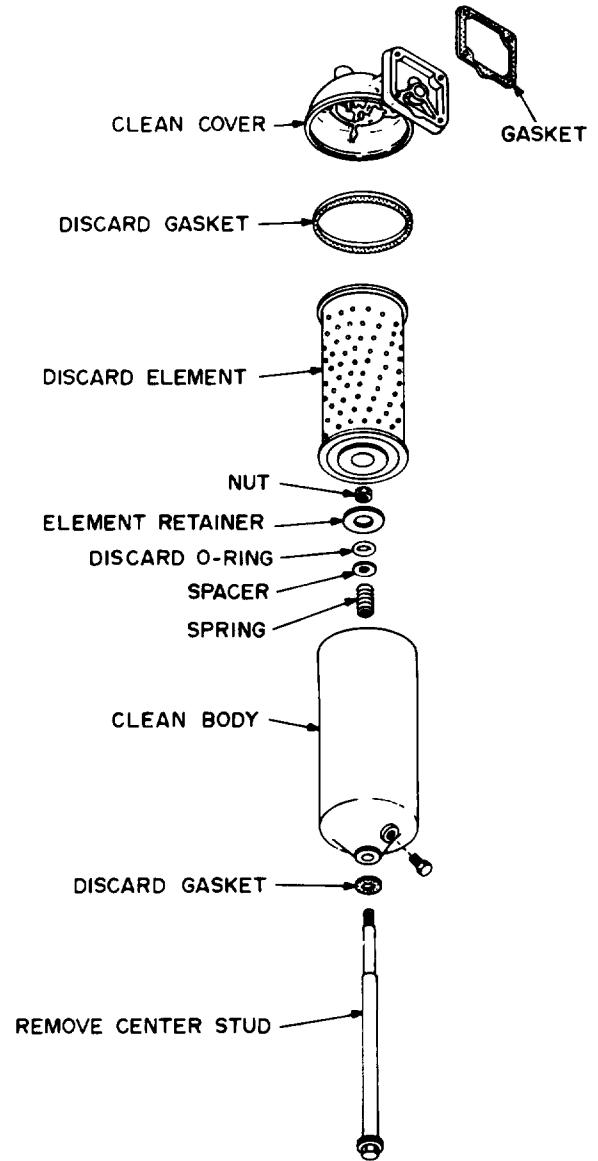

TA072394

Figure 4-2. Oil filter service.

4-13. Crankcase Breather

a. *Removal.* Refer to figure 4-3 and remove the crankcase breather.

b. *Cleaning and Inspection.*

WARNING

Compressed air used for cleaning purposes will not exceed 30 psi. Use only with effective chip guarding and personal protective equipment (goggles/shield, gloves, etc.)

(1) Wash the inside of the crankcase breather with drycleaning solvent (item 1, App F). Dry with compressed air.

(2) Inspect the crankcase breather for cracks and bends.

c. *Installation.* Refer to figure 4-3 and install the crankcase breather.

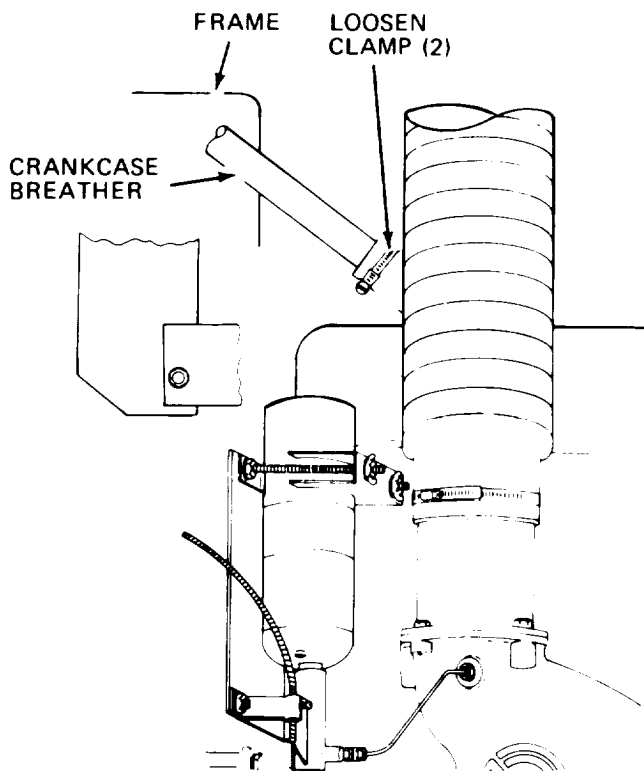

NOTE: REMOVE NUT AND SCREW THAT SECURE BREATHER TO FRAME.

TA031842

Figure 4-3. Crankcase breather, removal and installation.

4-14. Oil Level Dipstick

a. Refer to figure 4-4 for removal and installation, of the oil level dipstick.

b. Check, clean, and repair as required.

4-15. Oil Filler Pipe and Cap

a. *Removal.* Refer to figure 4-4 and remove the filler cap.

b. *Cleaning and Inspection.*

(1) Clean the oil filler pipe and cap with drycleaning solvent (item 1, App F) and *dry* thoroughly.

(2) Inspect the cap seal for deterioration. Replace a defective or damaged seal. Inspect the filler pipe and cap for cracks and damage. Replace a defective pipe or cap.

c. *Installation.* Refer to figure 4-4 and install the oil filler cap.

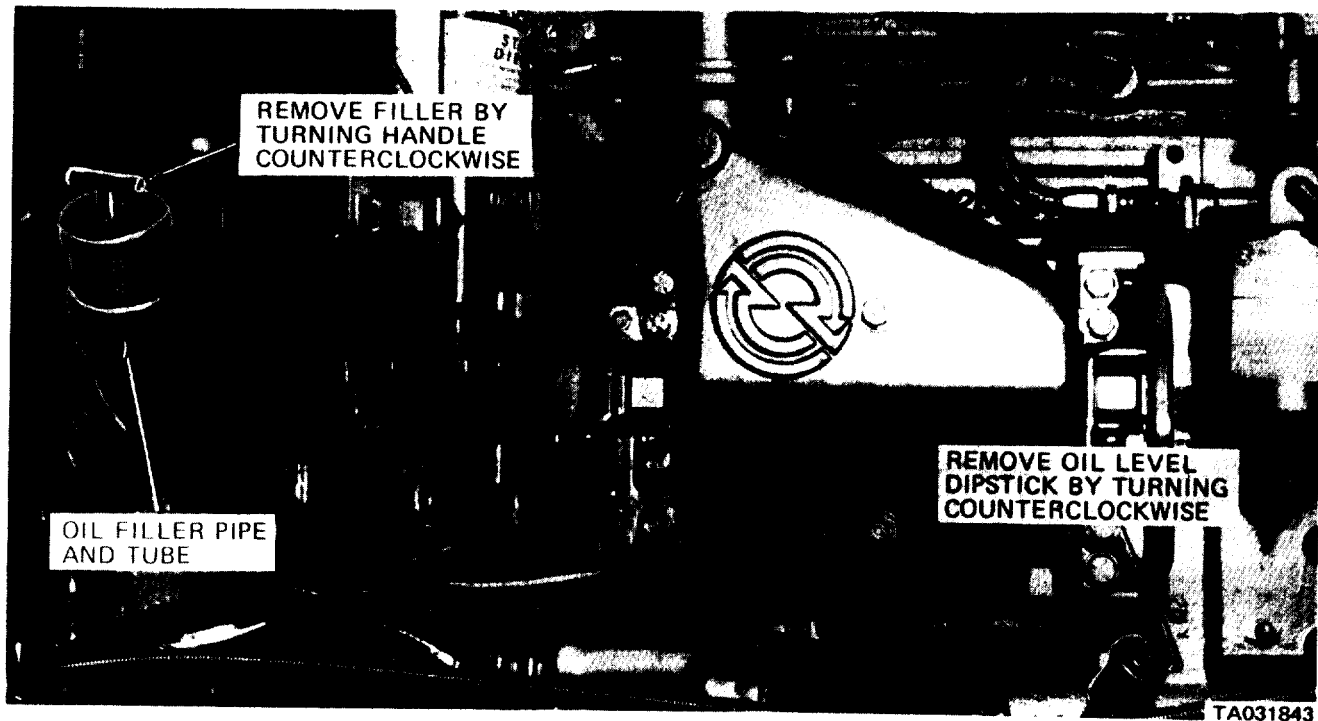

Figure 4-4. Oil level dipstick and oil filler pipe and cap, removal and installation.

Section VII. MAINTENANCE OF EXHAUST SYSTEM

WARNING

Drycleaning solvent, P-D-680, used to clean parts is potentially dangerous to personnel and property. Do not use near open flame or excessive heat. Flash point of solvent is 138° F.

4-16. General

This section contains information for organizational maintenance of components of the exhaust system.

This includes the muffler and exhaust pipe.

4-17. Muffler and Exhaust Pipe

a. Removal. Refer to figure 4-5 and remove the muffler and exhaust pipe.

b. Inspection. Check muffler and exhaust pipe for leaks, cracks, dents, and holes. Replace a defective muffler.

c. Installation. Refer to figure 4-5 and install the muffler and exhaust pipe.

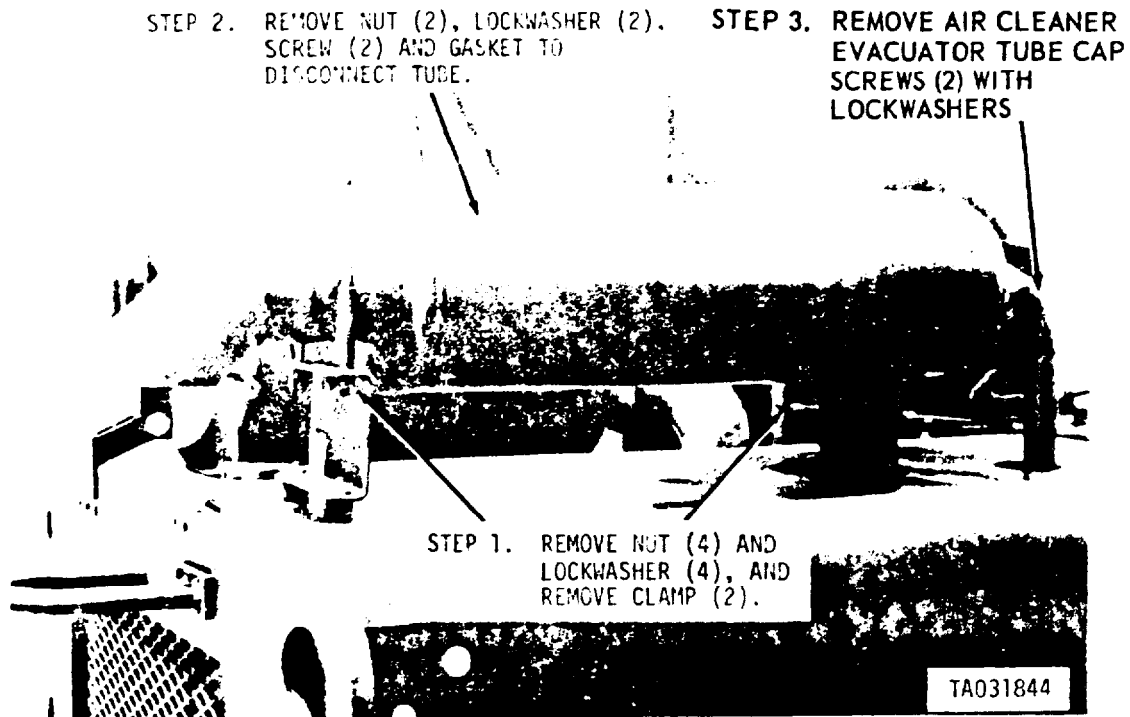

Figure 4-5. Muffler and exhaust pipe, removal and installation.

Section VIII. MAINTENANCE OF FUEL SYSTEM

WARNING

Drycleaning solvent, P-D-680 Used to clean parts is potentially dangerous to personnel and property. Do not use near open flame or excessive heat. Flash point of solvent is 138° F.

4-18. General

This section contains information for organizational maintenance of the fuel system. This includes the fuel pump, air cleaner and hose, and fuel filter.

4-19. Fuel Pump

a. *Removal* Refer to figure 4-6 and remove the fuel pump.

b. *Cleaning and Inspection.*

(1) Clean the fuel pump with drycleaning solvent (item 1, App F), and dry thoroughly.

(2) Inspect the fuel pump for cracks, breaks, or other damage. Replace if defective.

c. *Installation.*

(1) Affix a new gasket to the body of the pump and locate the pump drive coupling over the square end of the fuel pump drive shaft.

(2) Refer to figure 4-6 and install the fuel pump.

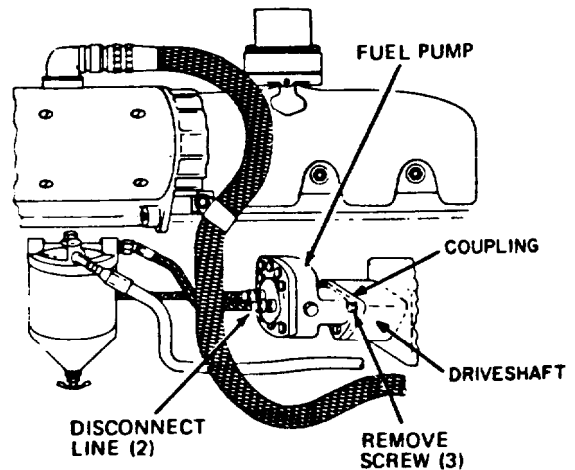

TA072395

Figure 4-6. Fuel pump, removal and installation.

4-20. Engine Air Cleaner

WARNING

If NBC exposure is suspected, all air after media should be handled by personnel wearing protective equipment. Consult your unit NBC or NBC NCO for appropriate handling or disposal procedures.

a. Service. Refer to figure 4-7 for servicing the air cleaner.

b. *General.* Service the primary filter when the air cleaner restriction indicator is red.

(2) Cleaning

(a) The primary filter element can be cleaned by reverse flushing, compressed air, or washing in water. Compressed air is recommended when the element is to be reused immediately. An element that has been washed in water should be dried thoroughly before reuse. Water is the best cleaning agent and should be used when soot or oil has plugged the element. The filter element should be replaced after six cleanings or annually. The safety filter element must be replaced at every third primary element service.

WARNING

Compressed air used for cleaning purpose will not exceed 30 psi. Use only with effective guarding and

personal protective equipment goggles/shield, gloves, etc).

NOTE

The safety filter element should not be cleaned and reused.

(b) When using compressed air, direct the air from inside the element to the outside, being careful not to rupture the element. Insure O-ring is properly seated and no leaks exist, Insure that the filter restriction indicator indicates in the green while engine is running.

(c) When using water to clean the element, soak the element for at least 15 minutes in a detergent and water solution. Rinse with a hose until water runs clean. The maximum allowable water pressure is 40 psi.

(d) Allow the element to dry thoroughly before using. Do not use compressed air or light bulbs to dry a wet element.

(3) *Inspection.*

(a) Inspect the filter element by placing a bright light inside and rotating the element slowly. If any rupture or holes are discovered, replace element.

(b) inspect the air cleaner body, inlet stack, and rain cap for damage. Replace defective parts.

(4) *Installation.*

(a) Refer to paragraph 4-7 and install the air cleaner elements.

(b) Reset the restriction indicator to green.

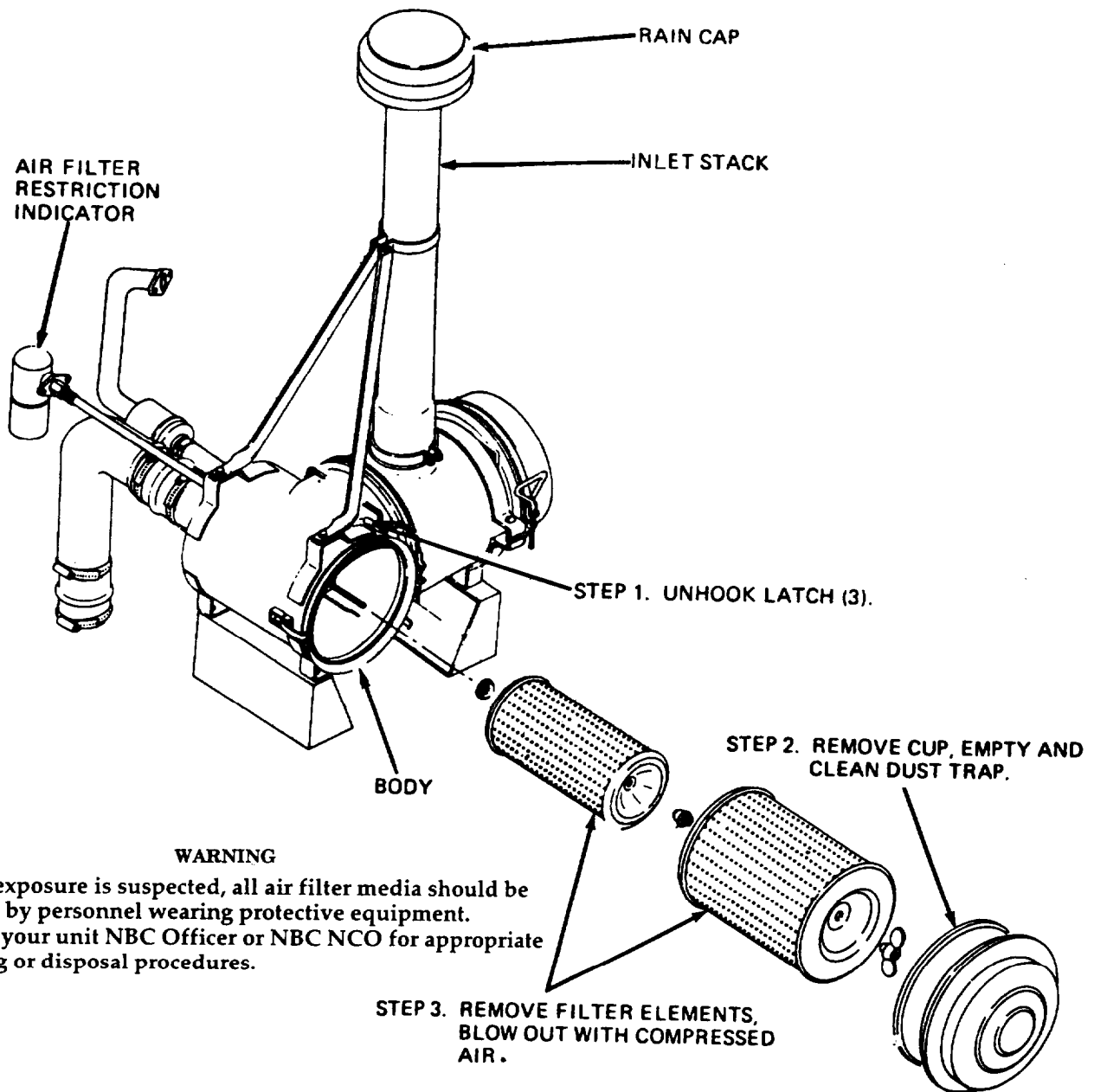

WARNING

NBC exposure is suspected, all air filter media should be handled by personnel wearing protective equipment. Consult your unit NBC Officer or NBC NCO for appropriate handling or disposal procedures.

Figure 4-7. Air cleaner servicing.

NOTE: AFTER SERVICE, REINSTALL FILTER ELEMENTS, REINSTALL CUP AND HOOK LATCH

4-21. Air Cleaner Assembly

a Removal. Refer to figure 4-8 and remove the air cleaner assembly.

b. Cleaning and Inspection

(1) Flush the air cleaner body with water or compressed.

(2) Clean all tubes and make sure they are open. Use a fiber brush to clean tubes.

(3) Empty the dust cap and clean the air cleaner stack.

(4) Inspect hoses for damage and defective connections.

(5) Replace all defective or worn parts.

c. Assembly and Installation. Refer to figure 4-8 and assemble and install the air cleaner assembly.

CAUTION

Be sure hose and hose connections are leak-proof. Insure that the air cleaner cover is properly secured. Unfiltered air can cause serious damage to the engine.

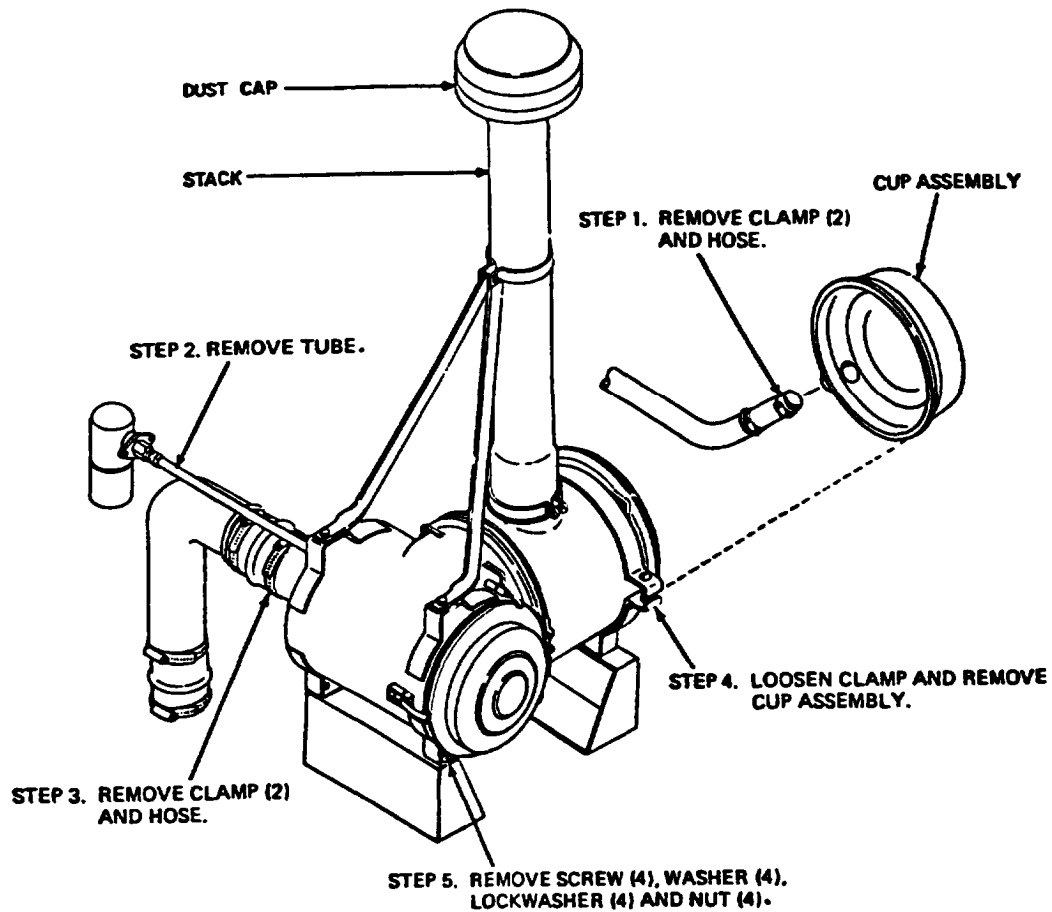

Figure 4-8 Air cleaner assembly, removal and installation.

TA072396

4-22. Fuel Filters

a. General. Change the secondary filter every 250 hours of operation and service the primary filter every 50 hours.

b. Removal. Refer to figure 4-9 and remove the primary and secondary fuel filters.

c. Cleaning and Inspection

(1) Refer to figure 4-10 and service the fuel filters.

(2) Inspect hoses for deterioration and cuts. Inspect the body and head for cracks and breaks. Replace defective parts.

d. Installation. Refer to figure 4-9 and install the primary and secondary fuel filters. Use new gaskets and be sure the mounting surfaces are clean.

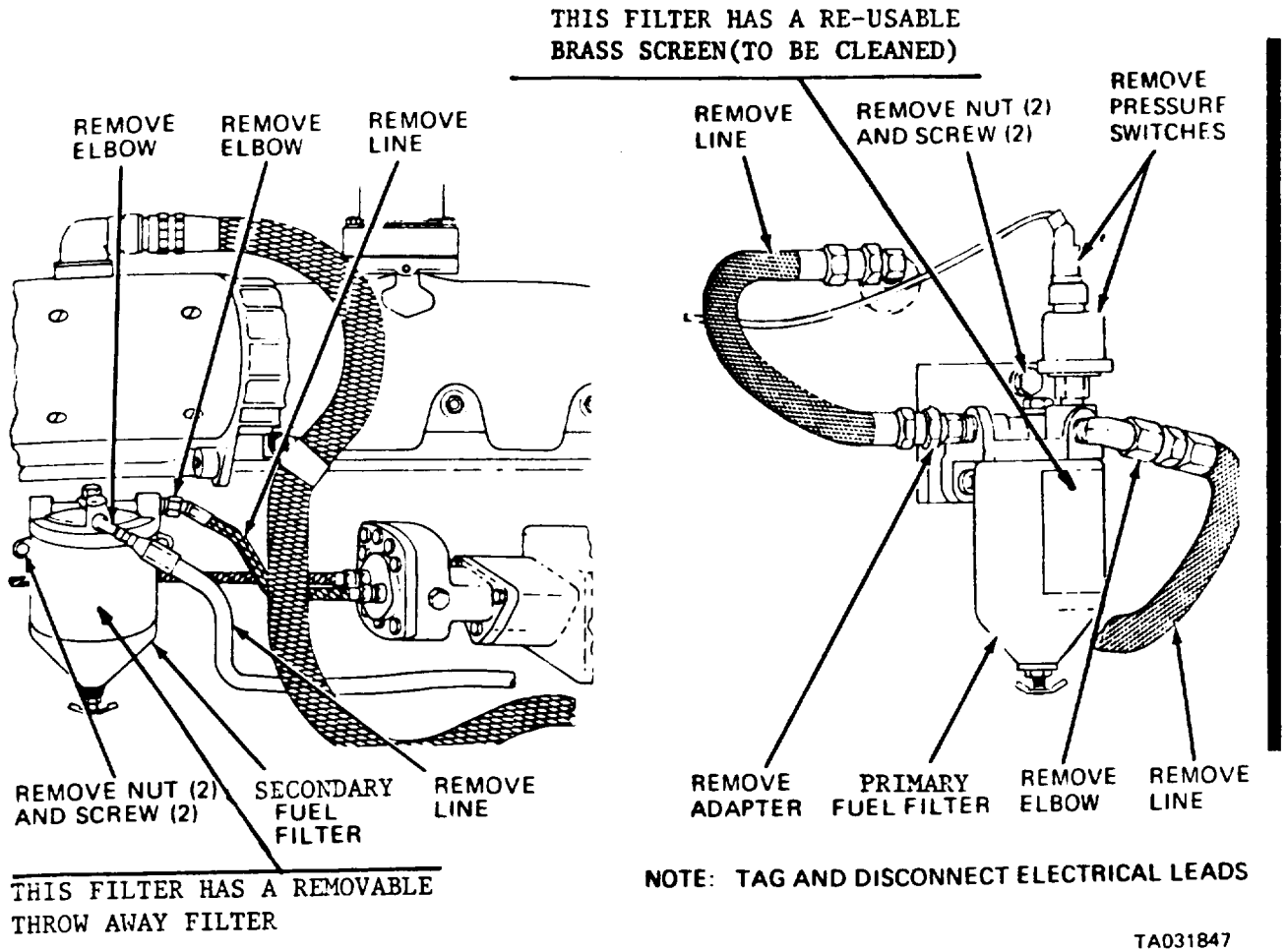
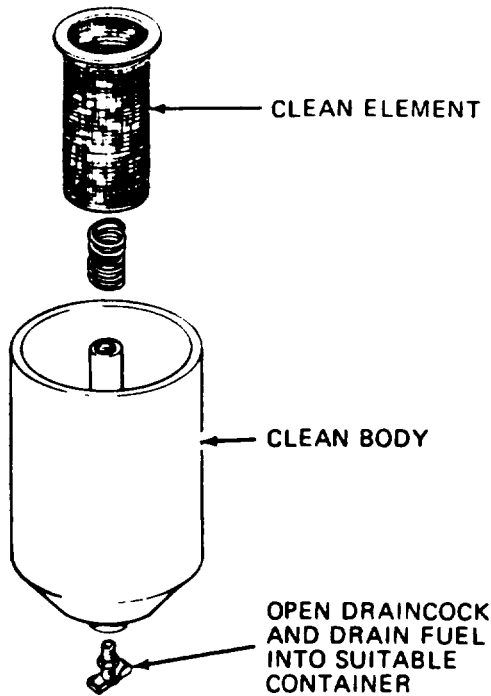
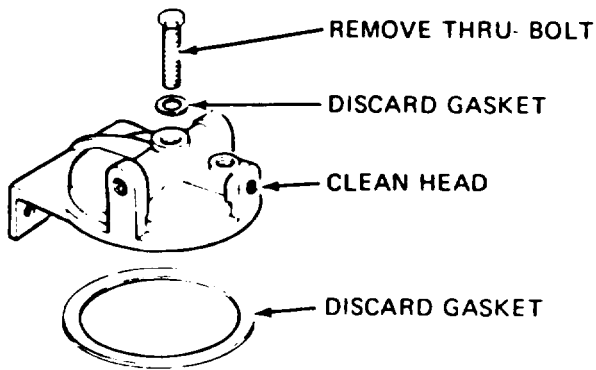
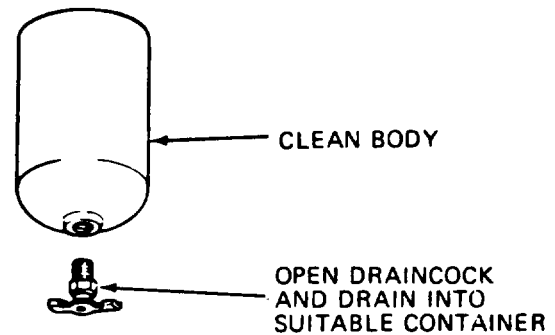
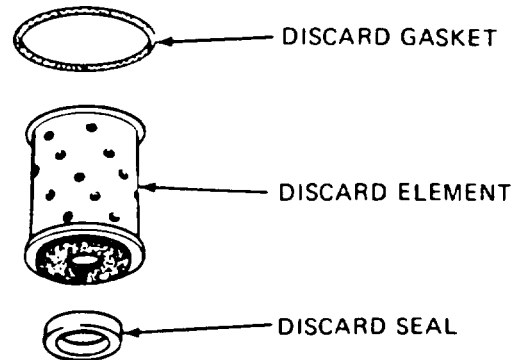
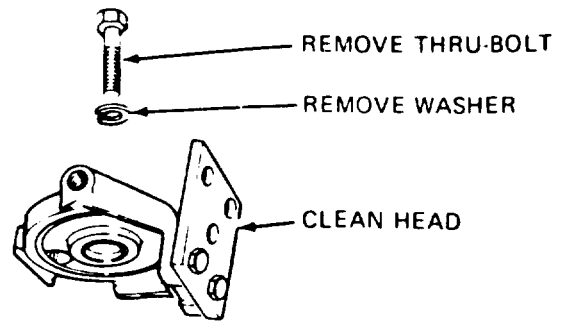

Figure 4-9. Fuel filters, removal and installation.



A. PRIMARY FUEL FILTER



B. SECONDARY FUEL FILTER

Figure 4-10. Fuel filter service.

TA031848

Section IX. MAINTENANCE OF COOLING SYSTEM

WARNING

Drycleaning solvent, P-D-680, used to clean parts is potentially dangerous to personnel and property. Do not use near open flame or excessive heat. Flash point of solvent is 138°F.

4-23. General

The diesel engine is cooled by circulating the engine coolant through the radiator, transmission heat exchanger, engine block, and cylinder head. Coolant

is drawn from the bottom of the radiator by the water pump. During the warm-up period, when coolant temperature is below normal, the coolant is restricted by the thermostat. A bypass tube connected between the thermostat housing and the water pump provides circulation within the engine. As the coolant temperature rises above 160° to 170° F., the thermostat valve opens, restricting the bypass system, and coolant is circulated through the radiator. This section contains information for

organizational maintenance of the cooling system components.

4-24. Thermostat Housing and Thermostat

a. Removal.

(1) Drain the cooling system to a level below the thermostat housing by opening the drain valve at the bottom of the radiator.

(2) Refer to figure 4-11 and remove the thermostat housing and thermostat.

b. Cleaning and Inspection

(1) Clean the thermostat housing seat and gasket surface.

(2) Inspect the thermostat for accumulation of rust and corrosion.

c. *Testing.* Check operation of thermostat. If the thermostat remains closed, overheating of the engine will result. If the thermostat remains open, the engine may not reach normal operating temperature, resulting in incomplete fuel combustion and carbon buildup. To check the operation of the thermostat, suspend it and a thermometer in a container of water. Do not let the thermometer of thermostat touch the bottom or sides of the container. Heat and agitate the water to maintain an even temperature. As the water is heated, the thermostat should begin to open at 160° to 170° F. and be fully open at approximately 190° F.

d. Installation

(1) Affix a new gasket to the thermostat housing and seat the thermostat in its housing so that the spring (or bellows) is down or toward the hot water side when the unit is bolted to the cylinder head.

(2) Refer to figure 4-11 and install thermostat housing and thermostat.

STEP 1. LOOSEN CLAMP AND DISCONNECT HOSE.

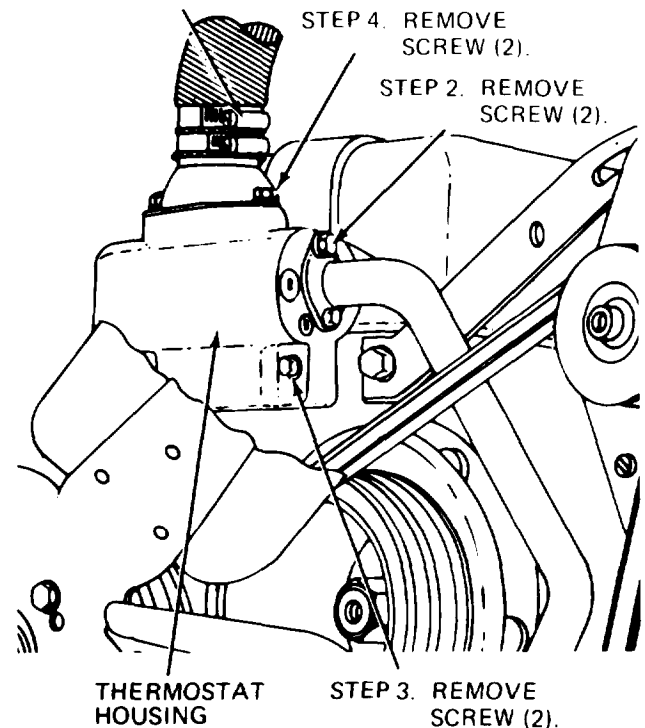

NOTE: REMOVE THERMOSTAT FROM THERMOSTAT HOUSING AFTER HOUSING IS REMOVED.

TA031849

Figure 4-11. Thermostat housing and thermostat, removal and installation.

4-25. Water Pump and Pulley

a. Inspection.

(1) Check water pump for leaks, excessive end play, and noise. Check drive belt tension.

(2) Check pulley and hub for cracks, breaks, loose or missing parts, or other damage.

b. Removal.

(1) Drain the cooling system. Refer to paragraph 4-28 and remove the generator and the water pump drive belts.

(2) Refer to figure 4-12 and remove the water pump and pulley.

c. Cleaning and Inspection.

(a) Clean the water pump housing with drycleaning solvent (item 1, App F) and dry thoroughly. Clean the water pump gasket surface, making sure the surface is clean.

(2) Inspect the water pump housing and pulley for cracks and damage. Make sure the water pump turns freely. Replace a defective pump.

d. Installation.

(1) Affix anew gasket to the pump body.

(2) Refer to figure 4-12 and install the water pump and pulley.

(3) Fill the cooling system.

(4) For repair of the pump, report to direct support maintenance.

(5) Refer to paragraph 4-28 and install the drive belts.

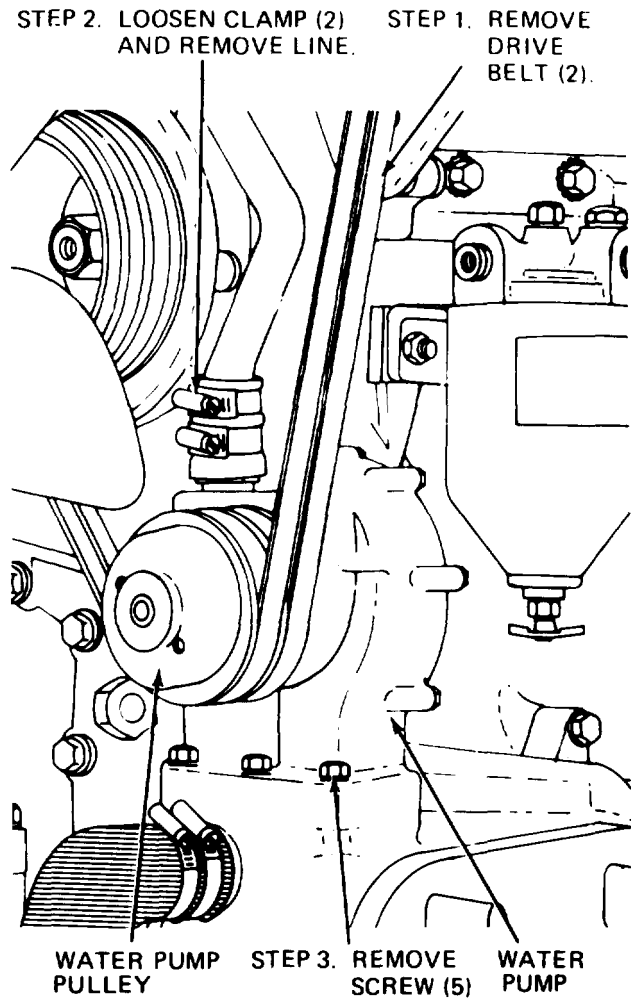

NOTE: USE A SUITABLE PULLER TO REMOVE WATER PUMP PULLEY

TA031850

Figure 4-12. Waterpump and pulley, removal and installation.

4-26. Coolant Hoses and Fittings

a. *Removal.* Drain the cooling system. Refer to figure 4-13 and remove coolant hoses and fittings.

b. *Clean and Inspection.*

(1) Clean hose fittings and gasket surfaces.

(2) Inspect fittings and surfaces for cracks and damage. Inspect hoses for deterioration and cuts. Replace defective parts and hoses.

c. *Installation.* Refer to figure 4-13 and install coolant hoses and fittings. Refill cooling system.

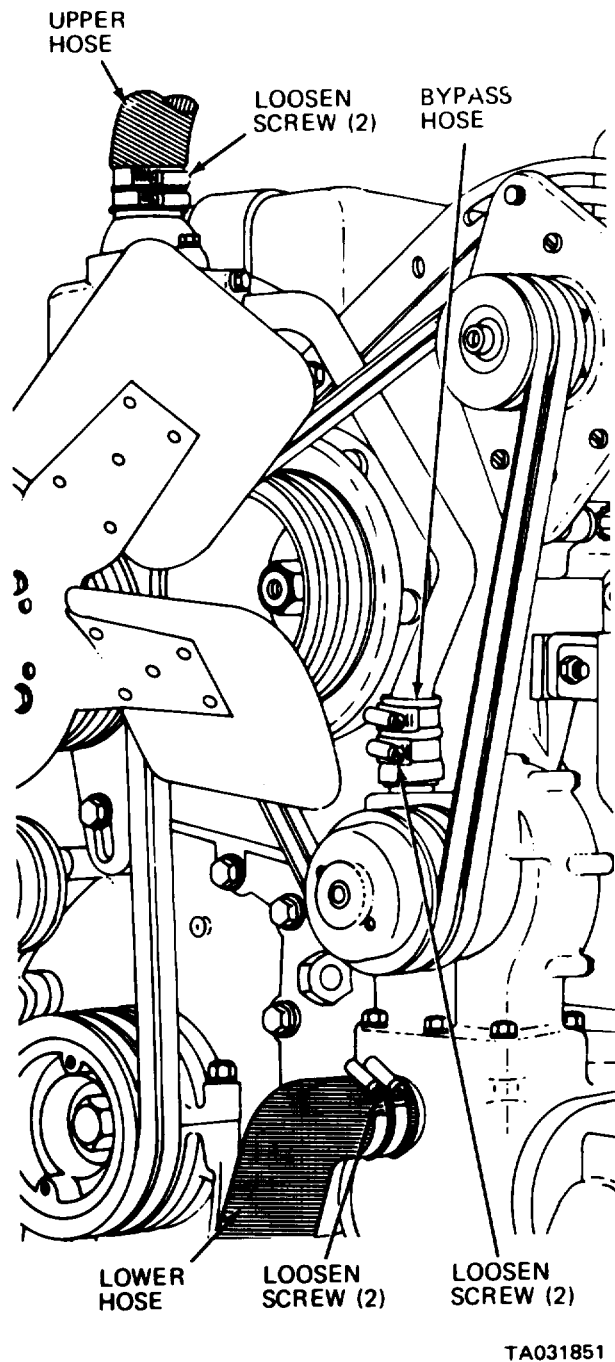

Figure 4-13. Coolant hoses and fittings, removal and installation.

4-27. Fan Guard

a. *Removal.* Refer to figure 4-14 and remove fan guard.

b. *Inspection.* Inspect the fan guard for cracks and breaks. Replace a defective fan guard.

c. *Installation.* Refer to figure 4-14 and install fan guard.

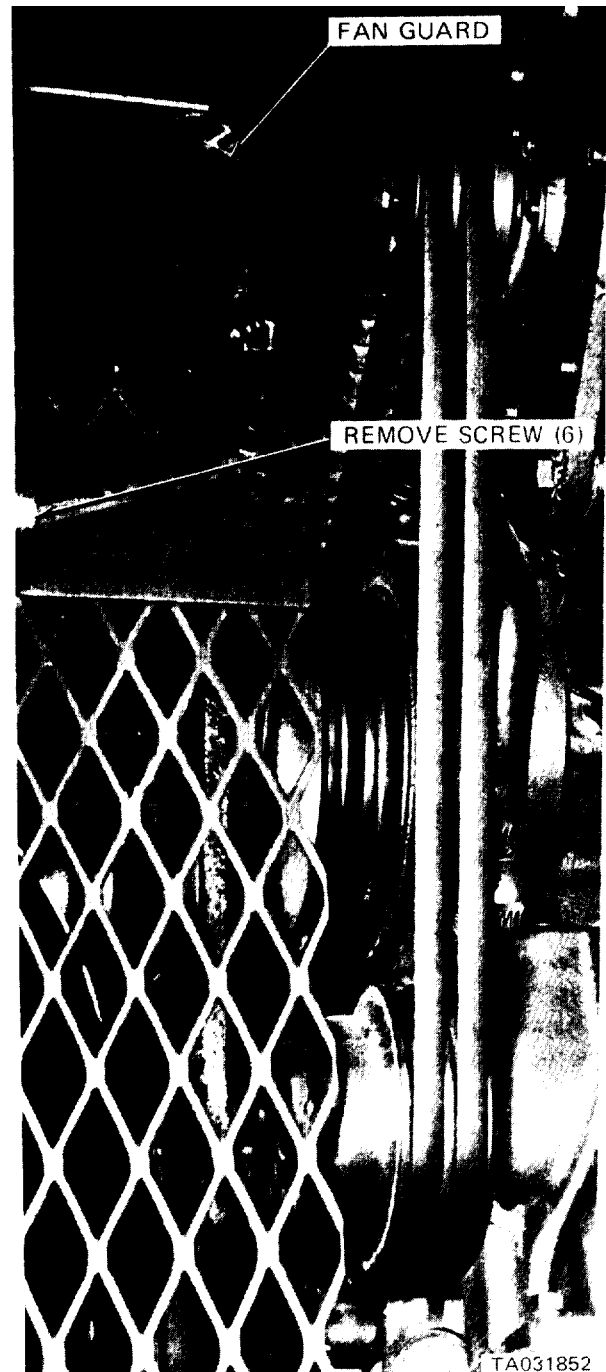
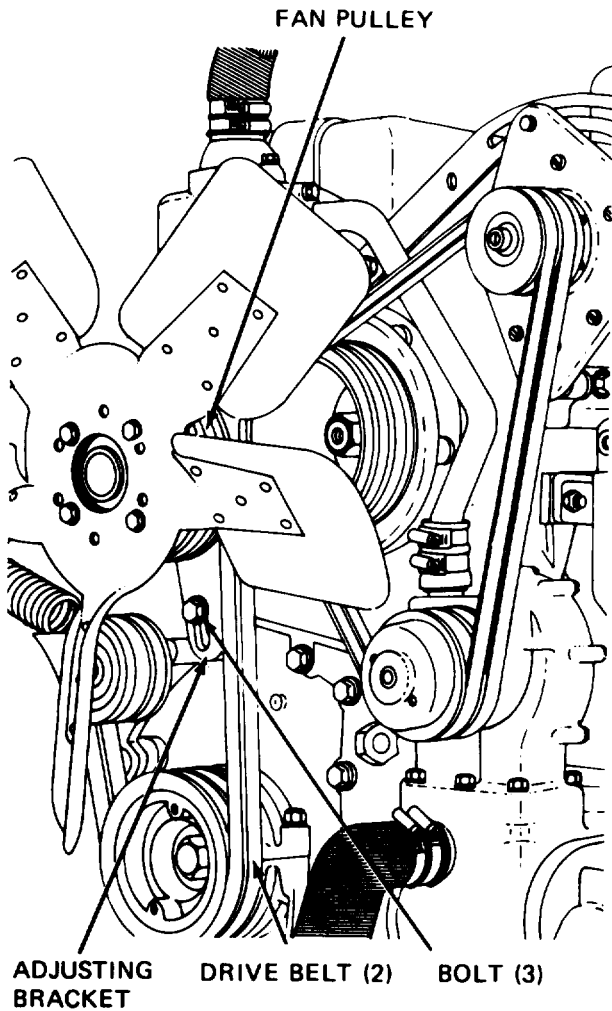

Figure 4-14. Fan guard, removal and installation.

4-28. Drive Belts

a. *Adjustment.* Inspect the drive belt tension. Belt deflection of one-half inch midway between

pulleys is evidence of correct belt tension. Refer to figure 4-15 to adjust belts.



A. FAN PULLEY

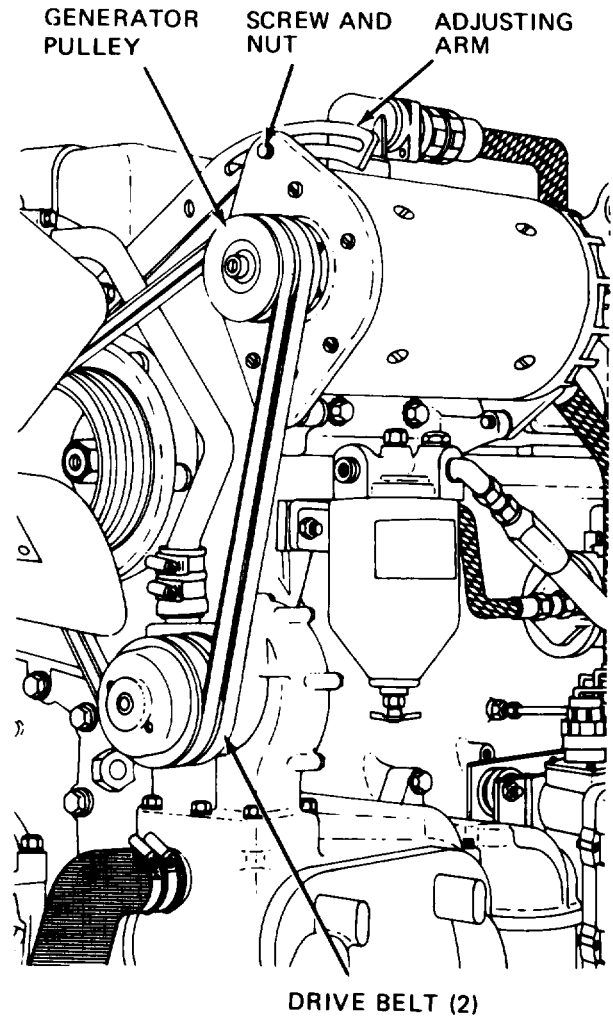

B. GENERATOR PULLEY

Figure 4-15. Drive belts adjustment.

TA031837

b. *Removal.* Refer to figure 4-16 and remove the generator and fan drive belts.

c. *Inspection.* Inspect the belts for cuts and deterioration. Replace defective belts.

d. *Installation.* Refer to figure 4-16 and install the generator and fan drive belts. Adjust in accordance with figure 4-15.

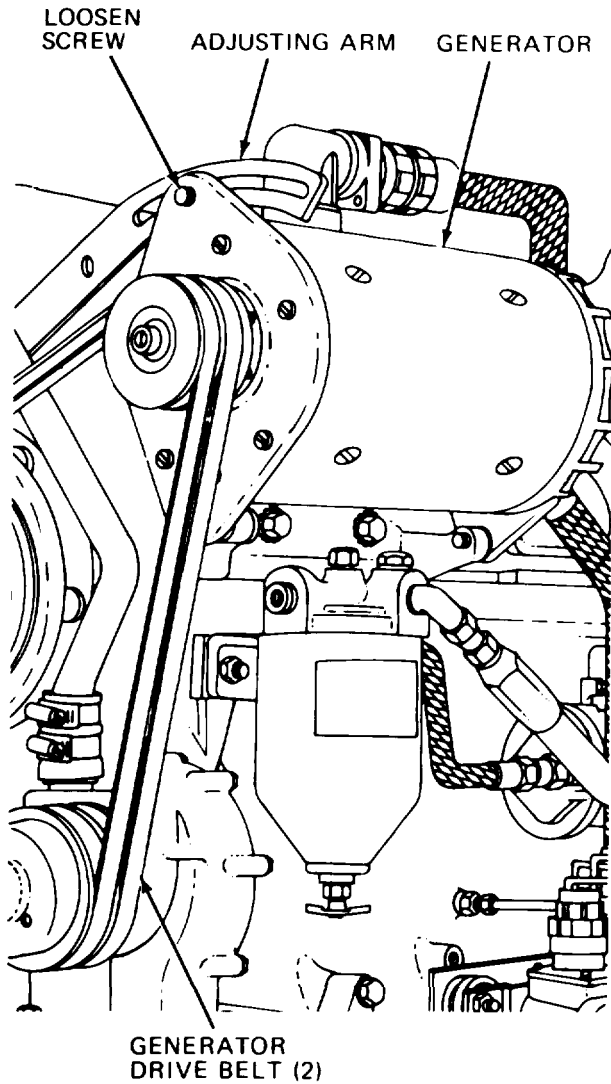

NOTE: LOOSEN SCREW AND MOVE GENERATOR TOWARD ENGINE UNTIL BELTS CAN BE REMOVED

A. GENERATOR DRIVE BELT

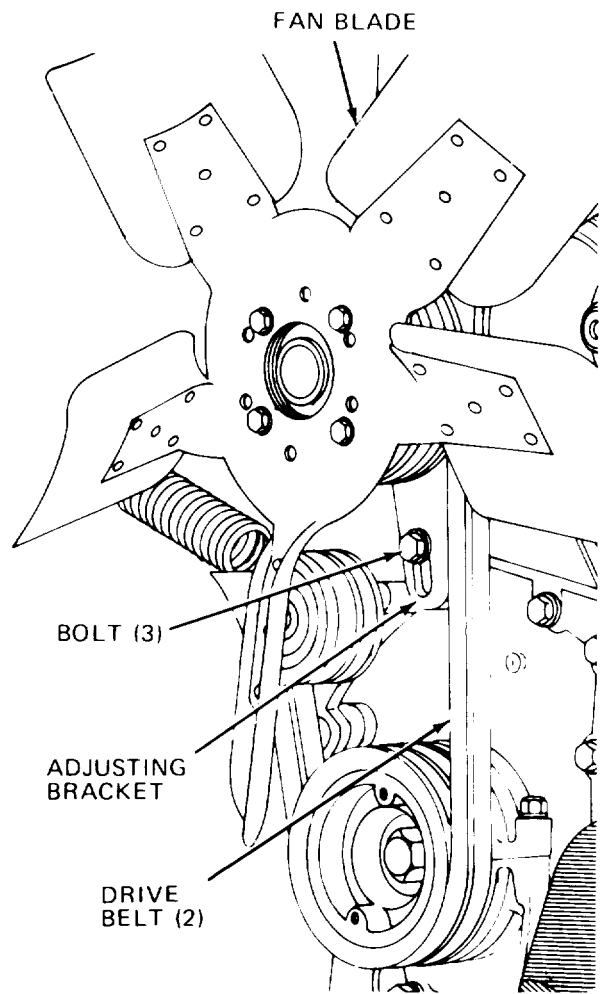

NOTE: LOOSEN BOLT (3) AND SLIP BELT (2) OVER FAN BLADE.

B. FAN DRIVE BELT.

TA031853

Figure 4-16. Drive belts, removal and installation.

4-29. Fan Blade

a. Removal.

- (1) Refer to figure 4-14 and remove fan guard.
- (2) Refer to figure 4-17 and remove the fan blade.

b. Inspection. Inspect the fan blade for nicks, cracks, and breaks. Replace a defective fan blade.

c. Installation.

- (1) Refer to figure 4-17 and install the fan blade.
- (2) Refer to figure 4-14 and install the fan guard.

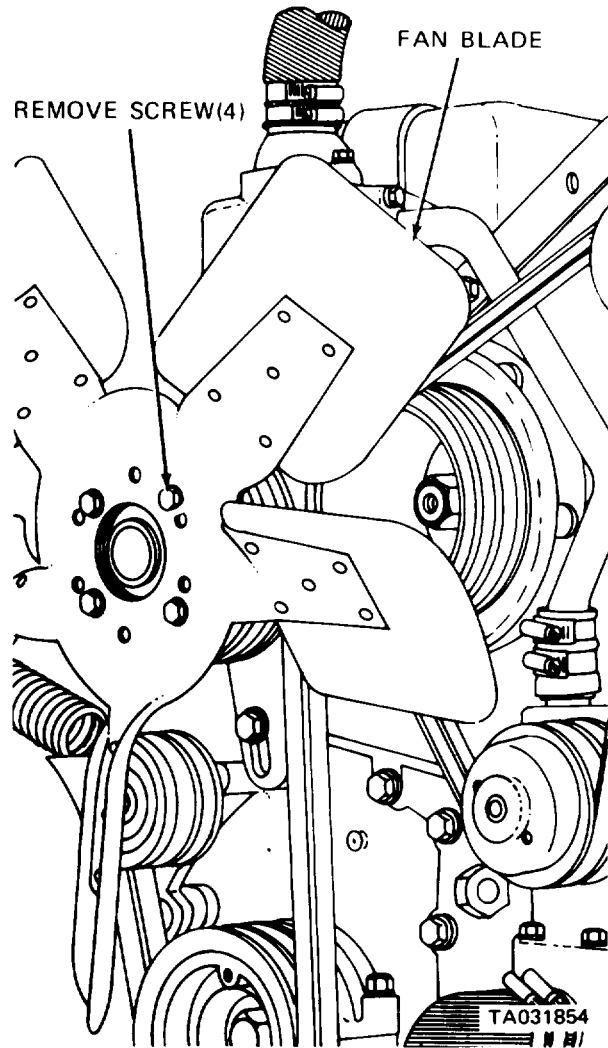

Figure 4-17. Fan blade, removal and installation.

4-30. Pulley and Hub

a. Removal.

- (1) Refer to figure 4-17 and remove the fan blade.
- (2) Refer to figure 4-18 and remove the pulley and hub.

b. Cleaning and Inspection.

- (1) Clean the pulley and hub with drycleaning

solvent (item 1, App F), and dry thoroughly.

- (2) Inspect the pulley and hub for cracks and breaks. Replace a defective pulley and hub.

c. Installation.

- (1) Refer to figure 4-18 and install the pulley and hub.
- (2) Refer to figure 4-17 and install the fan blade.

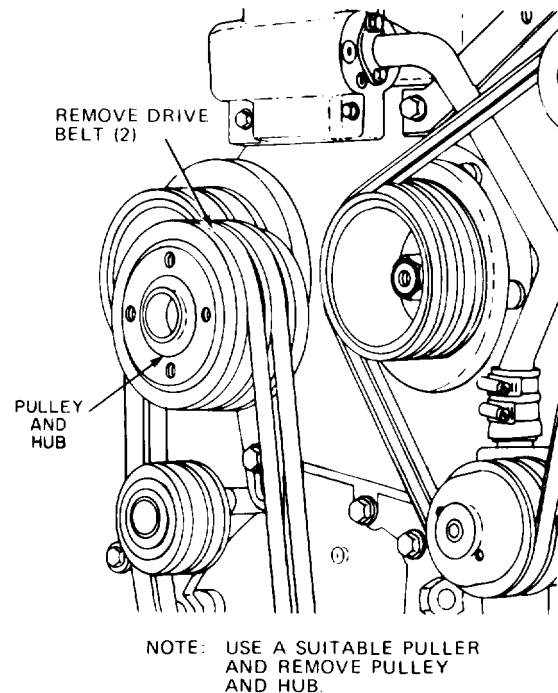

TA072397

Figure 4-18. Pulley and hub, removal and installation.

4-31. Fan Belt Tension Control, Spring, and Pulley Bracket

a. Removal.

- (1) Move the radiator fan control lever down to the ON position. In this position the spring is shortened and will permit the spring loop to be pulled from the bracket eye easily.
- (2) Refer to figure 4-19 and remove the fan belt tension control, spring, and bracket pulley.

b. Cleaning and Inspection.

- (1) Clean all parts with drycleaning solvent (item 1, App F) and dry thoroughly.
- (2) Inspect for cracks, rust, and breaks. Replace defective parts.

c. Installation.

- (1) Refer to figure 4-19 and install the fan belt tension control, and bracket pulley. Install the fan guard.
- (2) Move the radiator fan control lever down to the ON position to facilitate installation of the spring. Install spring. Move fan control lever to the OFF position.

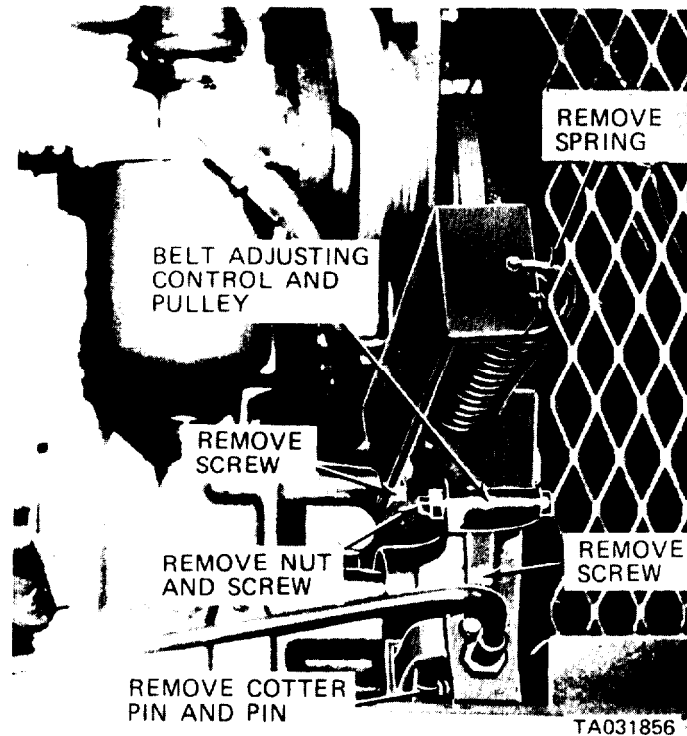

Figure 4-19. Fan belt tension control spring, and bracket pulley, removal and installation.

Section X. MAINTENANCE OF ELECTRICAL SYSTEM

WARNING

Drycleaning solvent, P-D-680, used to clean parts is potentially dangerous to personnel and property. Do not use near open flame or excessive heat. Flash point of solvent is 138°F.

4-32. General

This section contains information for organizational maintenance of the electrical system.

WARNING

Before disconnecting any electrical components, make sure battery cables are disconnected at batteries to prevent a serious burn or shock to personnel or damage to equipment. Disconnect battery ground cable first. When reconnecting batteries, starter, or any bare, unprotected wires, coat with silicone rubber adhesive.

4-33. Engine Generator

a On-Equipment Testing of Generator and Voltage Regulator.

(1) Refer to figure 4-20 and install adapter P/N 7052-103 in the generator receptacle. (Adapter, P/N

7052-103 is a part of adapter set NSN 4910-00-348-7600).

(2) When a high-charging rate with fully charged batteries is indicated, operate the unit at half throttle and disconnect the field jumper. If the output remains high, the fault is in the generator. If the output drops to zero, the fault is in the regulator. Replace a defective regulator and/or generator.

(3) When a low or no-charging rate with partially or fully discharged batteries, inspect for loose connections or damaged wiring. If none are found, stop the engine and disconnect the field jumper. Momentarily connect a jumper wire between the field terminal and the positive terminal of the batteries to polarize the generator. Reconnect the field jumper and start the engine. If the charging rate does not increase as the engine speed is increased, slow the engine and connect a jumper wire between the armature and field terminals. If the charging rate does not increase as the engine speed is increased, the generator is faulty. Replace a defective generator and/or regulator.

b. Removal. Refer to figure 4-21 and remove the engine generator.

c. Cleaning and Inspection.

(1) Clean generator housing and bracket with drycleaning solvent (item 1, App F) and dry thoroughly.

(2) Inspect the generator and bracket for

cracks, breaks, and loose or worn bearings. Check wiring for cuts and deterioration.

d. *Installation.* Refer to figure 4-21 and install the engine generator.

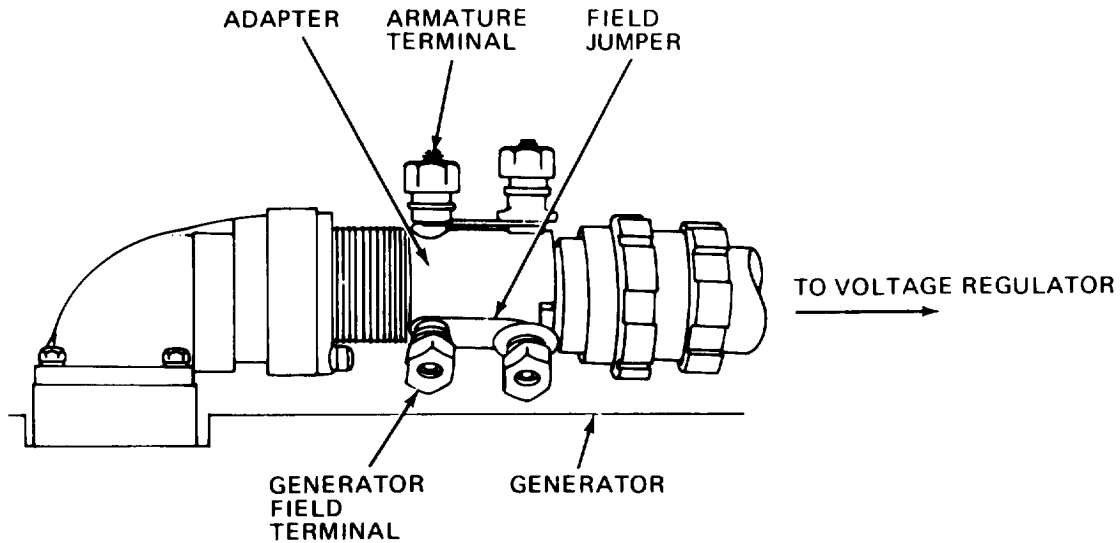

TA031857

Figure 4-20. Engine generator and voltage regulator, one-equipment testing.

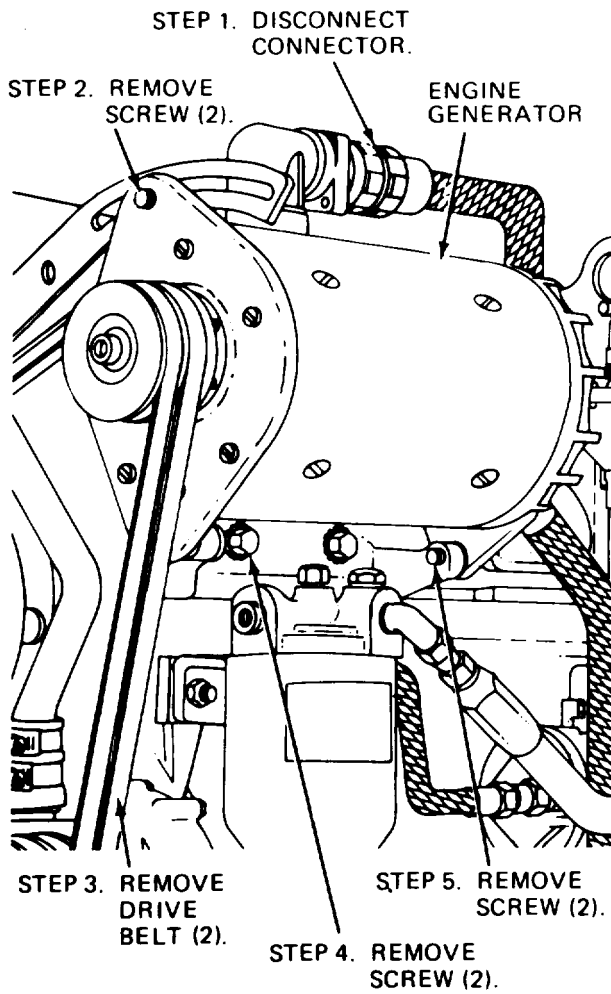

TA031858

Figure 4-21. Engine generator, removal and installation.

4-34. Battery Holddown Cover, Batteries, and Cables

WARNING

Always disconnect battery ground cable first to prevent serious burn or shock to personnel.

a. Removal.

(1) Disconnect battery ground cable. Refer to figure 4-22 and remove the positive, negative, and jumper cables as shown.

(2) Remove four wingnuts and lift out the battery holddown cover.

(3) Lift out the two batteries.

b. Cleaning and Inspection.

(1) Clean the battery holddown cover, batteries, and cables.

(2) Inspect the cover for cracks and breaks. Check batteries for corrosion and proper electrolyte level. Inspect cables for security and corrosion. Replace defective parts. Refer to TM 9-6140-200-14 for maintenance of batteries.

c. *Painting.* Paint the battery areas as necessary with an acid resistant paint to prevent corrosion.

d. Installation.

(1) Install the two batteries in the case.

(2) Install the battery holddown cover and secure with the four wingnuts.

CAUTION

This is a negative ground system. Reversing polarity will damage the voltage regulator. Be sure all battery connections are clean and secure.

(3) Refer to figure 4-22 and connect the positive, negative, and jumper cables as shown. Connect battery ground cable.

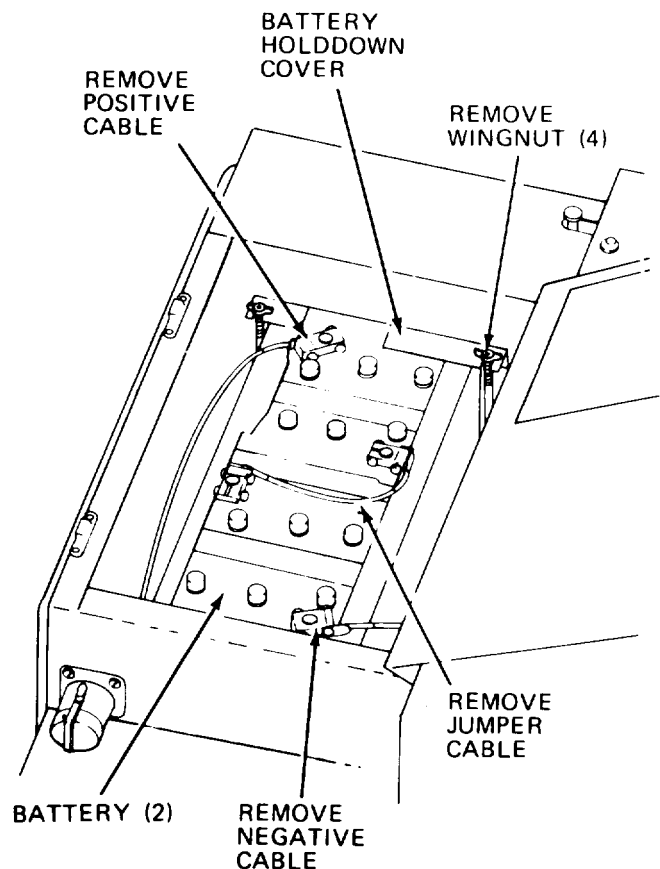

TA031859

Figure 4-22. Battery holddown cover, batteries, and cables, removal and installation.

4-35. Receptacle Slave Connector

a. *Removal.* Refer to figure 4-23 and remove the receptacle slave connector.

b. *Inspection.* Inspect for corrosion and broken or frayed wires. Replace defective parts.

CAUTION

When cables are replaced, insure that the positive (+) cable is attached to the large

battery post connector and that the negative (-) cable is grounded to the engine. When installing the receptacle, place the positive (+) connector up in relation to its mounted position. Failure to do so will result in damage to the forklift.

c. *Installation.* Refer to figure 4-23 and install the receptacle slave connector.

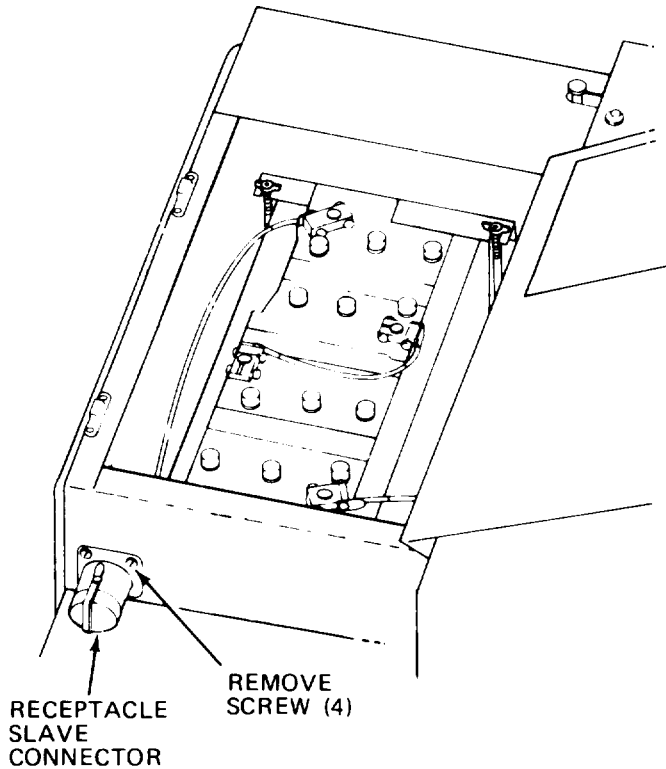

NOTE: TAG AND DISCONNECT ELECTRICAL LEADS AS NECESSARY.

TA031860

Figure 4-23. Receptacle slave connector, removal and installation.

4-36. Voltage Regulator and Bracket

a. *On-Equipment Testing.* Refer to paragraph 4-33a and test voltage regulator and engine generator.

b. *Removal.* Tag electrical leads. Refer to figure 4-24 and remove the voltage regulator and bracket.

c. *Cleaning and Inspection.*

(1) Clean the voltage regulator and bracket with drycleaning solvent (item 1, App F) and dry thoroughly.

(2) Inspect bracket for cracks or breaks. Inspect voltage regulator for loose hardware, corrosion, and damaged connectors. Replace all defective parts.

d. *Installation.* Refer to figure 4-24 and install voltage regulator and bracket.

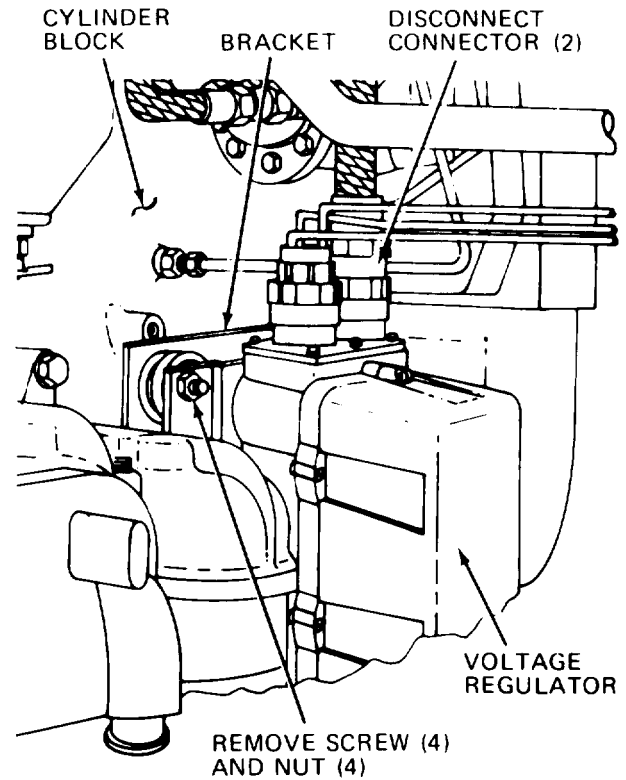

NOTE: REMOVE NUT (4) AND SCREW (8) THAT SECURE VOLTAGE REGULATOR AND BRACKET TO CYLINDER BLOCK,

TA031861

Figure 4-24. Voltage regulator and bracket, removal and installation.

4-37. Starter and Solenoid

a. *Removal.* Refer to figure 4-25 and remove the starter and solenoid.

b. *Cleaning and Inspection.*

(1) Clean the starter and solenoid with drycleaning solvent (item 1, App F) and dry thoroughly.

(2) Inspect the starter mounting hardware and housing for cracks and breaks. Inspect wiring for cuts and deterioration. Inspect for corrosion.

c. *Installation.* Refer to figure 4-25 and install the starter and solenoid.

NOTE

When replacing starter with new starter P/N 1114717, the engine oil dipstick must be moved or otherwise altered or clear the new starter.

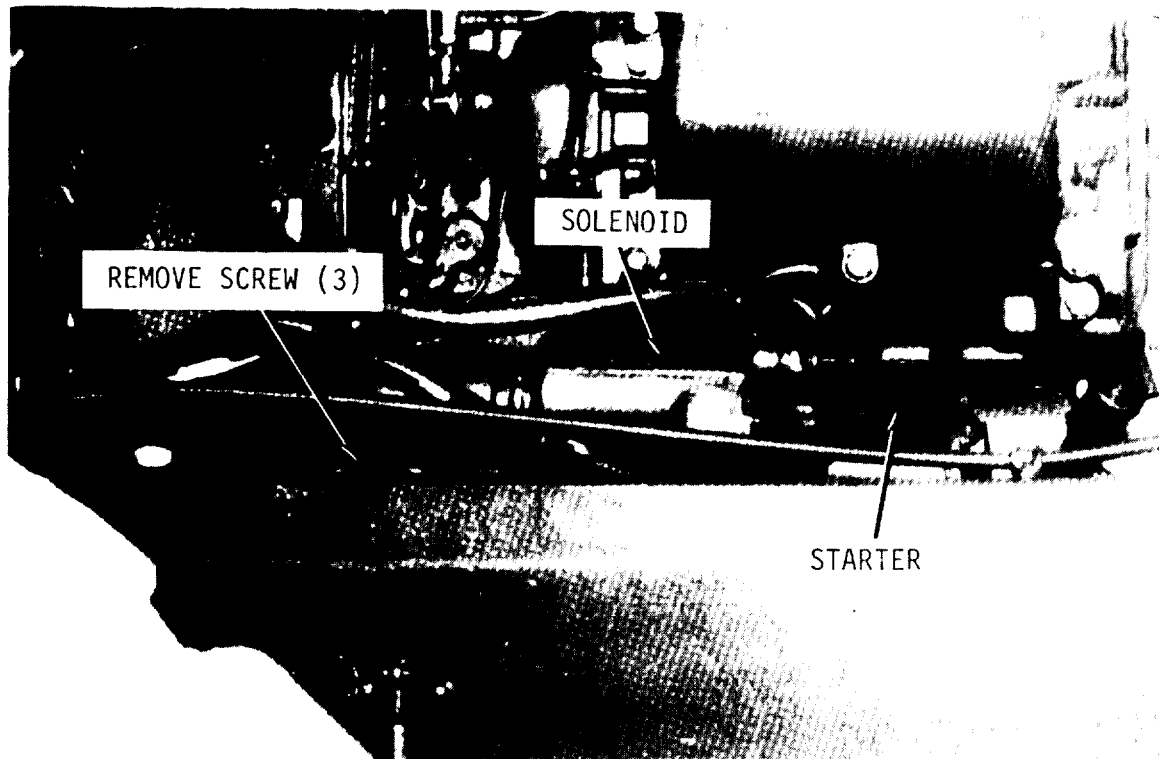

NOTE: TAG AND DISCONNECT ELECTRICAL LEADS

TA031862

Figure 4-25. Starter and solenoid, removal and installation.

4-38. Neutral Start Switch

a. Removal. For access to the neutral start switch, raise the forks to the fully raised position. The switch is located on the right front side of the transmission. Refer to figure 4-26 and remove the neutral start switch.

b. Cleaning and Inspection.

(1) Clean the neutral start switch and *directional control linkage* with dry-cleaning solvent (item 1, App F) and dry thoroughly.

(2) Inspect the switch for corrosion. Check wiring for breaks and deterioration. Inspect linkage for loose hardware and damage. Replace defective parts.

c. Installation. Refer to figure 4-26C and install the neutral start switch.

d. Adjustments.

(1) Place FWD-NEUT-REV directional control lever (fig. 2-1) in the NEUT position.

(2) Loosen stop nut on linkage yoke (fig. 4-26B).

(3) Turn yoke until camshaft moves the cam, strikes the roller, and the switch is activated, allowing starter to engage.

(4) Make sure top and bottom directional linkage yokes are parallel when the directional control lever (fig. 2-1) is in NEUT and the high point of the cam is striking the rollers.

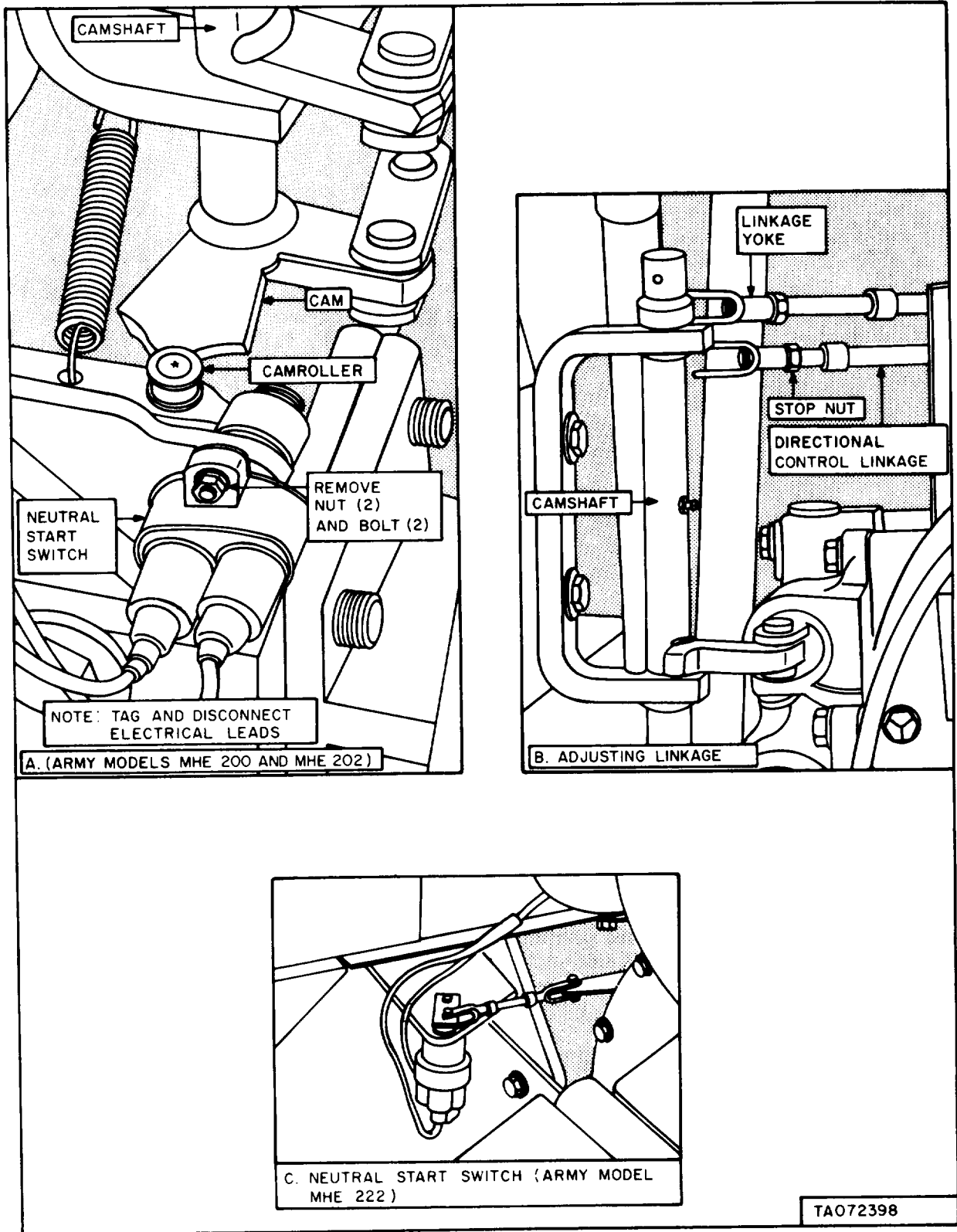

Figure 4-26. Neutral starts witch, removal, installation, and adjustment.

4-39. Brake Pressure Switch.

a. General. The pressure switch is located on the rearward structure member of the battery carrier, adjacent to the hydraulic oil tank. For access, remove the left engine side panel. From this access point, the device is located high and to the left. An alternate access is through the battery carrier, adjacent to the hydraulic oil tank. The switch is activated when the accumulator hydraulic pressure drops below 300 psi and a buzzer warning indicates that it is unsafe to operate the forklift truck.

b. Testing.

(1) Disconnect one of the two wire leads that go to the brake pressure switch.

(2) Start and operate the engine for at least one minute to build up the hydraulic oil pressure in the accumulator.

(3) Using a multimeter, and with one wire lead disconnected, test for continuity across the two wire lead terminals. There should be no continuity indicated.

(4) Stop the engine and operate the brake pedal several times until you are sure that all hydraulic pressure in the accumulator is exhausted.

(5) Again, test across the terminals. This time there should be continuity indicated.

(6) Replace a defective brake pressure switch.

c.. Removal

WARNING

Always bleed off the pressure before opening any part of the hydraulic brake system by operating the brake pedal several times while the engine is not running. Failure to observe this warning may result in severe injury to personnel.

(1) Bleed off hydraulic pressure by operating the brake pedal until all pressure has been depleted.

(2) Refer to figure 4-27 and remove the brake pressure switch.

d. Cleaning and Inspection.

(1) Clean the brake pressure switch with a cloth that has been dampened in drycleaning solvent (item 1, App F). Do not immerse the switch in solvent or allow it to be saturated by solvent.

(2) Inspect the switch for corrosion, cracks, damaged, and other damage. Replace a defective switch.

e. Installation. Refer to figure 4-27 and install the brake pressure switch.

STEP 1. TAG AND DISCONNECT ELECTRICAL LEAD (2).

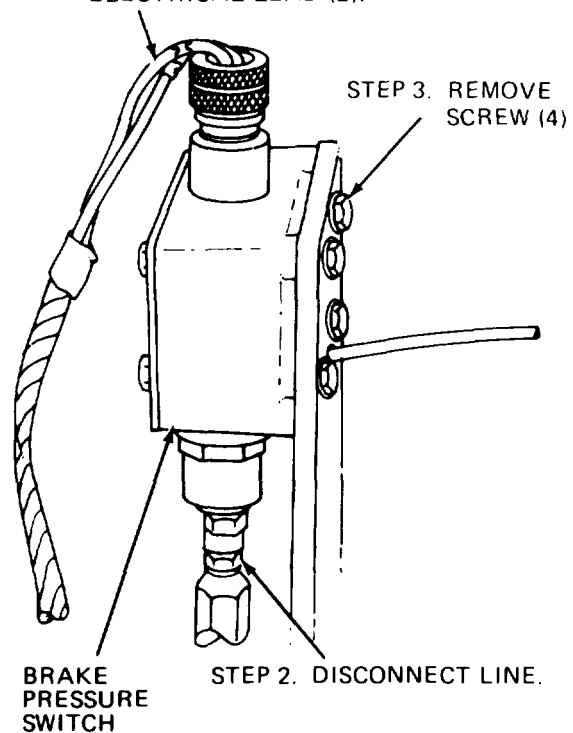

TA031864

Figure 4-27. Brake pressure switch, removal and installation.

4-40. Starter Pressure Switch and Magnetic Switch

a Magnetic Switch.

(1) *Inspection.* Inspect switch for corrosion and loose connections. Check wiring for breaks and deterioration. Replace defective parts.

(2) *Removal.* Tag and remove the four electrical wires. Refer to figure 4-28 and remove mounting screws and nuts.

(3) *Installation.* Refer to figure 4-28 and install the magnetic switch.

b. Starter Pressure Switch.

(1) *Inspection.* Inspect switch for corrosion and loose connections. Check wiring for breaks and deterioration. Replace defective parts.

(2) *Removal.* Tag and remove electrical wire. Refer to figure 4-28 and unscrew switch from its mounting hole.

(3) *Installation.* Refer to figure 4-28 and install the starter pressure switch.

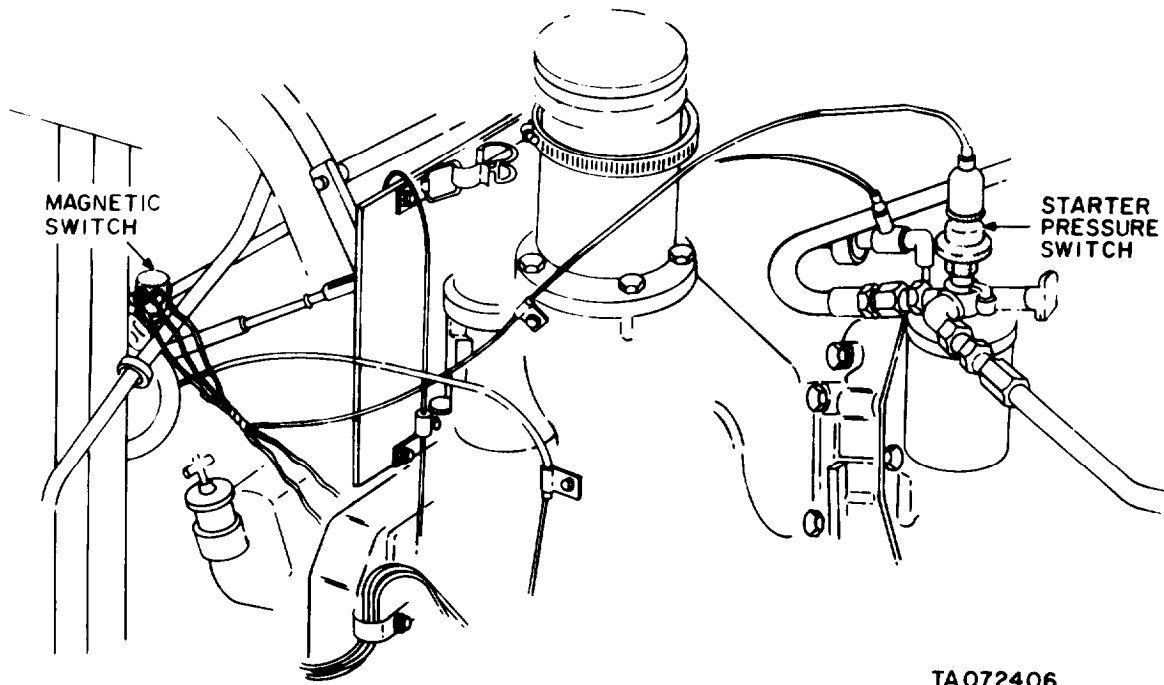

TA072406

Figure 4-28. Starter pressure switch and magnetic switch.

4-41. Stoplights, Blackout Lights, Headlights, Horn, and Taillights.

a Removal. Refer to figure 4-29 and remove stoplights, blackout lights, headlights, horn, and taillights.

b. Cleaning and Inspection.

WARNING

Compressed air used for cleaning purposes will not exceed 30 psi. Use only with effective chip guarding and personal protective equipment (goggles/shield, gloves, etc.)

(1) Clean the stoplights, blackout lights, headlights, and taillights lenses with a damp cloth and dry thoroughly. Clean horn with low pressure compressed air.

(2) Inspect all lights for cracked or broken lenses, loose hardware, and functioning light bulbs. Inspect all wiring to lights and horn for cuts and deterioration. Replace all defective parts.

c. Installation. Refer to figure 4-29 and install stoplights, blackout lights, headlights, horn, and taillights.

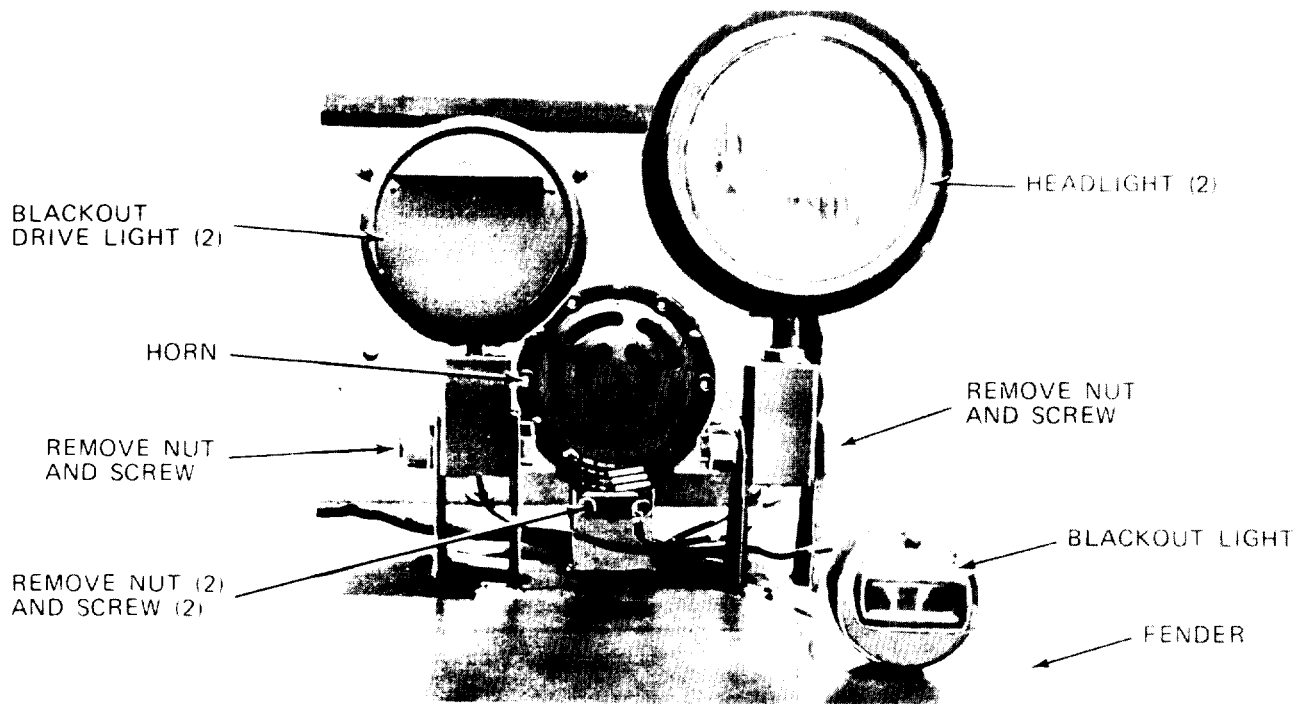

NOTE: TAG AND DISCONNECT ELECTRICAL LEADS AS NECESSARY.
 NOTE: REMOVE OTHER LIGHT IN A SIMILAR MANNER.

A. HEADLIGHT, HORN, AND BLACKOUT LIGHTS.

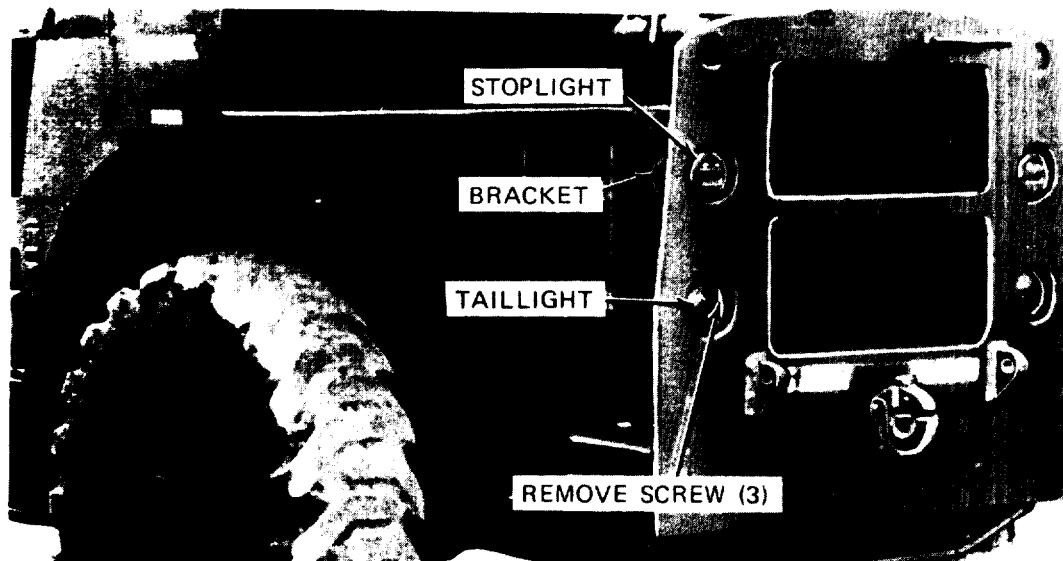

NOTE: REMOVE SCREW (2) THAT SECURE STOPLIGHT TO BRACKET.
 NOTE: TAG AND DISCONNECT ELECTRICAL LEADS AS NECESSARY.
 NOTE: REMOVE OTHER STOPLIGHT AND TAILLIGHT IN A SIMILAR MANNER.

B. STOPLIGHT AND TAILLIGHT

TA031865

Figure 4-29. Stoplights, blackout lights, headlights, horn and taillights, removal and installation.

4-42. Floodlights

a. *Removal* Refer to figure 4-30 and remove the floodlights.

b. *Cleaning and Inspection.*

(1) Clean the lens with a damp cloth and dry thoroughly.

(2) Inspect the floodlight for a cracked lens, missing or burned out bulbs, and loose hardware. Inspect wiring for cuts and deterioration. Replace defective parts.

c. *Installation.* Refer to figure 4-30 and install the floodlights.

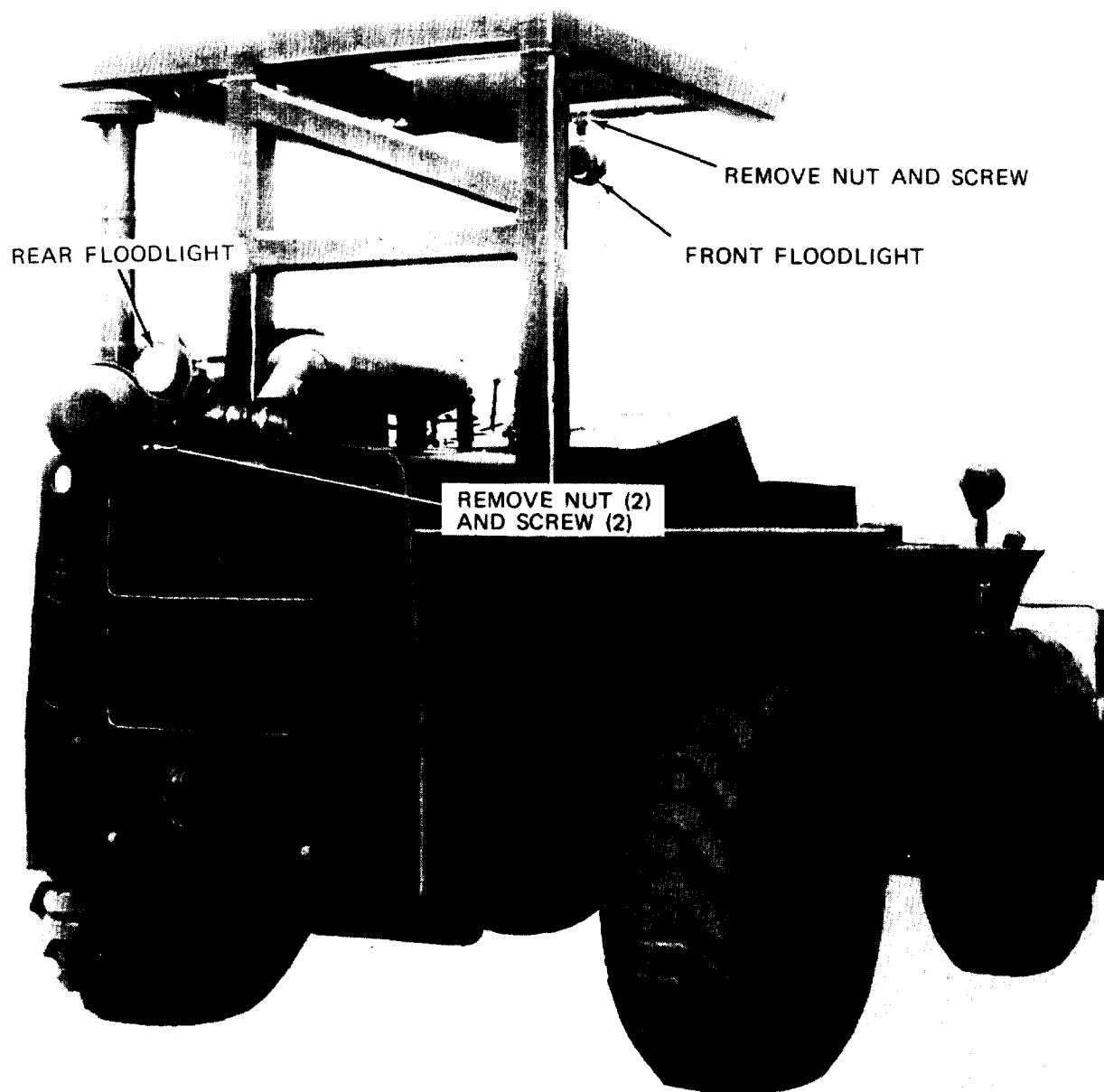

NOTE: TAG AND DISCONNECT ELECTRICAL LEADS AS NECESSARY

TA031866

Figure 4-30. Floodlights, removal and installation.

Section XI. MAINTENANCE OF CONTROLS AND INSTRUMENTS

WARNING

Drycleaning solvent, P-D-680, used to clean parts is potentially dangerous to personnel and property. Do not use near open flame or excessive heat. Flash point of solvent is 138°F.

4-43. General

This section contains information for organizational maintenance of the controls and instruments of the forklift truck.

WARNING

Disconnect battery (+) cable from battery before disconnecting any wiring under dash.

4-44. Engine Hourmeter

a. Removal. Refer to figure 4-31 for location of hourmeter. Tag and disconnect electrical lead. Remove six nuts, six screws, and three lockwashers attaching hour-meter to instrument panel and remove hourmeter.

b. Inspection and Testing.

(1) Inspect the hourmeter for broken glass. Inspect the electrical wiring for cuts, breaks, and deterioration.

(2) Connect hourmeter to a 24 volt power source and check for proper operation by checking indicator above odometer wheels. Indicator should revolve once per minute.

(3) Replace a defective hourmeter.

c. Installation. Install hourmeter in instrument panel using six screws, three lockwashers, and six nuts. Connect electrical lead.

4-45. Battery and Generator Indicator

a. Removal. Refer to figure 4-31 for location of battery and generator indicator. Tag and disconnect electrical connections. Remove three nuts and lockwashers and remove indicator from instrument panel.

b. Testing Test the battery and generator indicator by connecting it to an external 24-volt power source along with another voltmeter of known accuracy. Compare the readings of both meters to determine the accuracy of the indicator. The indicator readings should correspond as follows: red (lb), 18-22V; yellow, 22-26V; green, 26-30V; and red(rh), 30-34V.

c. Inspection. Inspect the battery and generator indicator for broken cover glass and loose electrical connections. Replace a defective indicator.

d. Installation. Install three mounting nuts and lockwashers to install battery and generator indicator in instrument panel.

4-46. Toggle Switches

a. General. The two toggle switches control the front and rear floodlights. Before removing switches, check operation in ON and OFF positions by observing operation of the floodlights. Before attributing a malfunction to a defective switch, make sure that lamps are not burned out and that electrical connections are correct.

b. Removal.

(1) Refer to figure 4-31 for location of the front and rear floodlight toggle switches.

(2) Tag and disconnect electrical connections.

(3) Remove two locknuts and remove switch from instrument panel.

c. Cleaning and Inspection.

WARNING

Compressed air used for cleaning purposes will not exceed 30 psi. Use only with effective chip guarding and personal protective equipment (goggles/shield, gloves, etc.)

(1) Clean toggle switches with an approved cleaning solvent and dry thoroughly, or use low pressure compressed air.

(2) Inspect switches for loose connections or broken hardware. Replace a defective switch.

d. Installation. Mount toggle switch on instrument panel using two locknuts. Reconnect electrical connections.

4-47. Panel Lights

a. Removal. Refer to figure 4-31 for location of panel lights. Disconnect electrical connector and remove two mounting screws to remove panel lights from instrument panel.

b. Inspection. Inspect the panel lights for loose connections, defective wiring, and missing or burned out light bulbs. Replace defective lights.

c. Installation. Use two screws to mount panel light on instrument panel. Connect electrical connector.

4-48. Starter and Horn Push Button Switches

a. Testing. Test for a defective switch by disconnecting leads from switch to horn or starter, and connecting a test light between the switch terminals. Push the button. If the test light does not light, the switch is defective.

b. Removal.

(1) Refer to figure 4-31 for location of starter and horn push button switches.

(2) Tag and disconnect electrical connections.

(3) Unscrew boot covering push button and remove switch.

c. Inspection. Inspect switches for corrosion, loose connections, and defective wiring. Replace a defective switch.

d. Installation.

(1) Screw boot and push button switch into instrument panel. Refer to figure 4-31 for proper location.

(2) Connect electrical connections.

4-49. Light Switch

a. General. The light switch controls the panel lights, headlights, taillights, marker lights, and blackout head lights and taillights. Operate switch and observe lights for proper operation. Check for burned out light bulbs and correct wiring before attributing failure to a defective switch.

b. Removal. Refer to figure 4-31 for location of light switch. Tag and disconnect electrical connections. Remove four screws that mount light switch to instrument panel and remove light switch.

c. Inspection. Inspect the light switch for cracks, breaks, loose connections, and defective or missing hardware. Replace a defective switch.

d. Installation. Use four screws to mount light switch to instrument panel. Connect electrical connections.

4-50. Hydraulic Control Levers.

a. Removal. Refer to figure 4-31 and remove the hydraulic control levers.

b. Cleaning and Inspection.

(1) Clean the *control* levers with drycleaning solvent (item 1, App F) and dry thoroughly.

(2) Inspect the hydraulic control levers for cracks, breaks, and loose hardware. Replace if found defective.

c. Installation. Refer to figure 4-31 and install the hydraulic control levers.

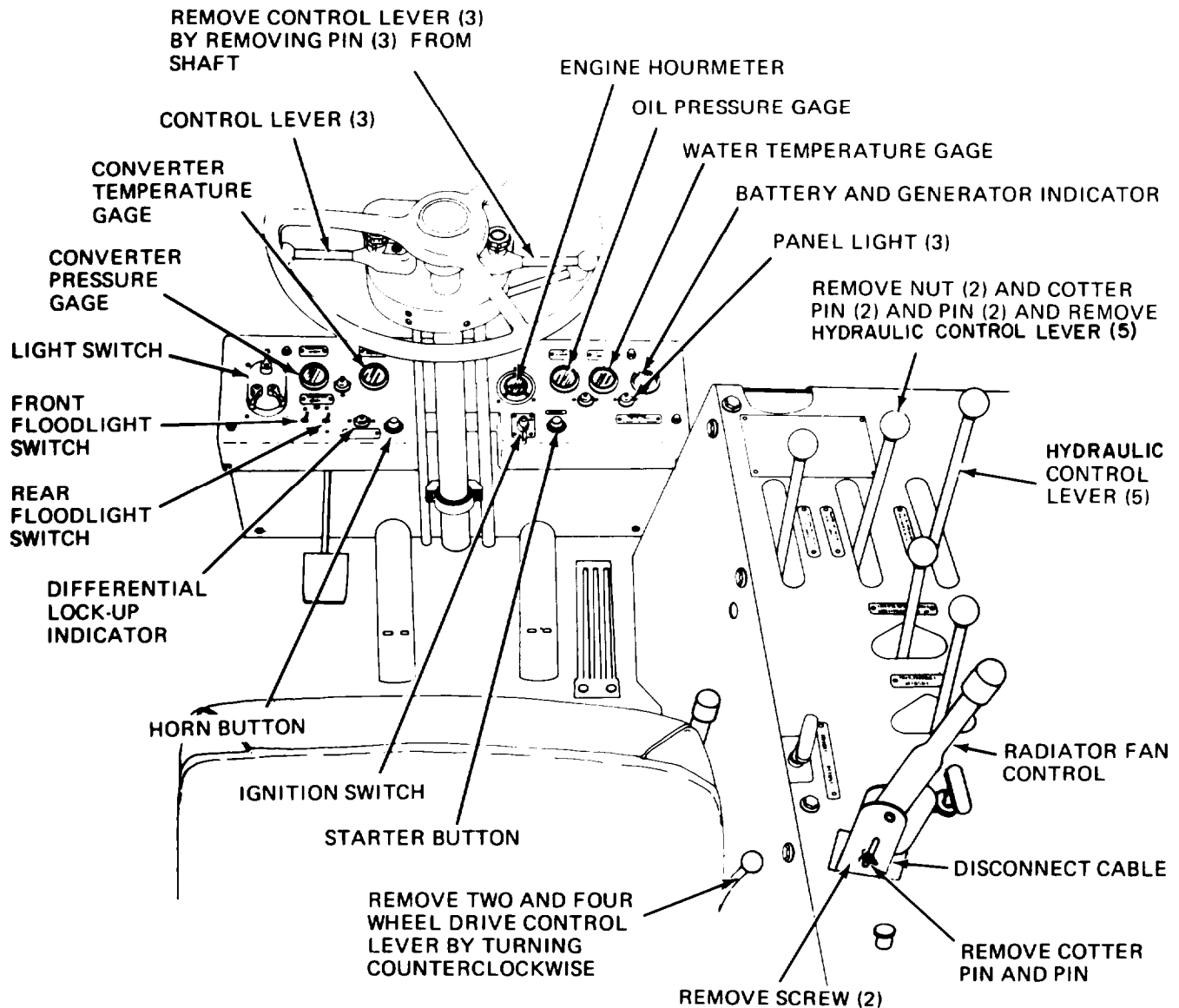

NOTE: TAG AND DISCONNECT ELECTRICAL LEADS AND REMOVE MOUNTING HARDWARE AS NECESSARY.

TA072399

Figure 4-31. Controls and instruments, removal and installation.

4-51. Differential Lockout Control

a. General. The differential lockout control is located on the firewall of the driver's compartment. When the lockout pedal is pressed, oil (OE 10) or brake fluid HBA (MIL-H-13910) is forced to the lockout mechanism, mounted on each differential. This action insures that each pair of driving wheels turn together.

NOTE

Brake fluid HBA (MIL-H-13910) is used

on Athey Model ARTFT-6, S/N Range F1468 thru F1596 and G1597 thru G1755 (NSN 3930-00-419-5744). It is also used on a limited number of Anthony Models MLTG-2, S/N 1098 thru 1159 and 1305 thru 1307 (NSN 3930-00-327-1475).

b. Removal. Refer to figure 4-32 and remove the lockout control.

c. Inspection and Service.

(1) Inspect the rubber boot and hoses for cuts

and deterioration. Check for loose connections. Tighten loose connections and replace all defective parts.

(2) To service, lift the rubber boot on the valve assembly and fill to within $\frac{3}{4}$ inch from top with OE 10 oil or brake fluid HBA (MIL-H-13910). Depress pedal several times and recheck fluid level. A

bleeder valve is provided at the lockout mechanism mounted on the differential to remove air from system. Replace the rubber boot on the valve assembly.

d. *Installation.* Refer to figure 4-32 and install the differential lockout control.

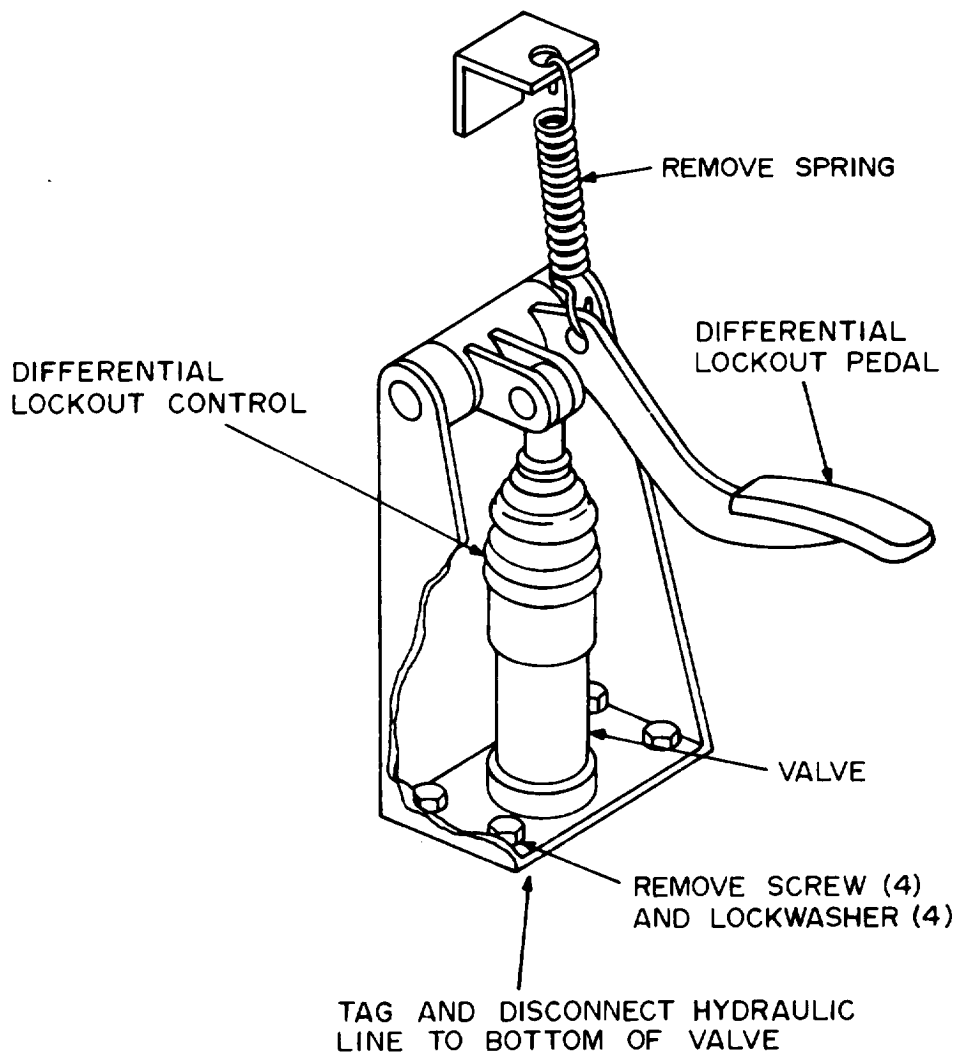

TA072427

Figure 4-32. Differential lockout control removal and installation.

4-52. Foot Controls

a. *Removal.* Refer to figure 4-33 and remove the foot controls as follows:

(1) *Brake Pedal and Inching Pedal.* Remove cotter pin and pin attaching each pedal to its linkage. Remove pedal.

(2) *Throttle Pedal.*

(a) Remove cotter pin and pin attaching pedal to throttle linkage.

(b) Remove two nuts, lockwashers, and screws attaching throttle pedal to mounting plate and cockpit floor. Remove pedal.

b. *Inspection.* Inspect the foot controls for broken or missing hardware, cracks, and damaged parts. Replace all defective parts.

c. *Installation.* Refer to figure 4-33 and install foot controls as follows:

(1) *Broke Pedal and Inching Pedal.* Bet pedals

in place and use cotter pin and pin to reconnect them to the correct control linkage.

(2) *Throttle Pedal.*

(a) Use two screws, nuts, and lockwashers to attach pedal to mounting plate and cockpit floor.

(b) Use cotter pin and pin to connect throttle pedal to the control linkage.

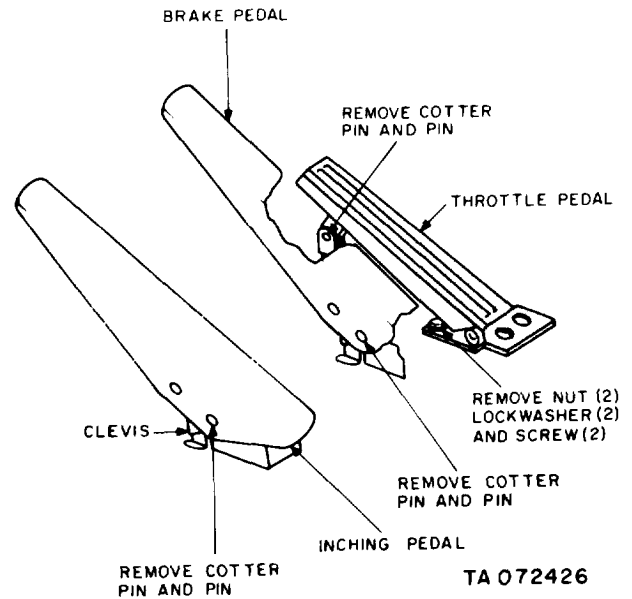

Figure 4-33. Foot Controls, removal and installation.

Section XII. MAINTENANCE OF TRANSMISSION

4-53. General

This section contains information for organizational maintenance of the transmission.

4-54. Transmission External Filter

a. Removal.

(1) Remove the forward panel under the right rear fender.

(2) Refer to figure 4-34 and remove the transmission external filter.

NOTE

Change filter element at every transmission oil change. The filter element is a throw away type paper element.

b. Cleaning and Inspection.

(1) Clean the filter head with an approved cleaning solvent and dry thoroughly. Make sure old gasket material is removed, and install a new filter element and gasket.

(2) Inspect the new filter for cracks, breaks, and loose connections. Check the oil for contamination.

c. Installation.

(1) Refer to figure 4-34 and install the transmission external filter.

(2) Service transmission in accordance with current lubrication order.

STEP 1. TAG AND DISCONNECT HYDRAULIC LINE AND FITTING (2).

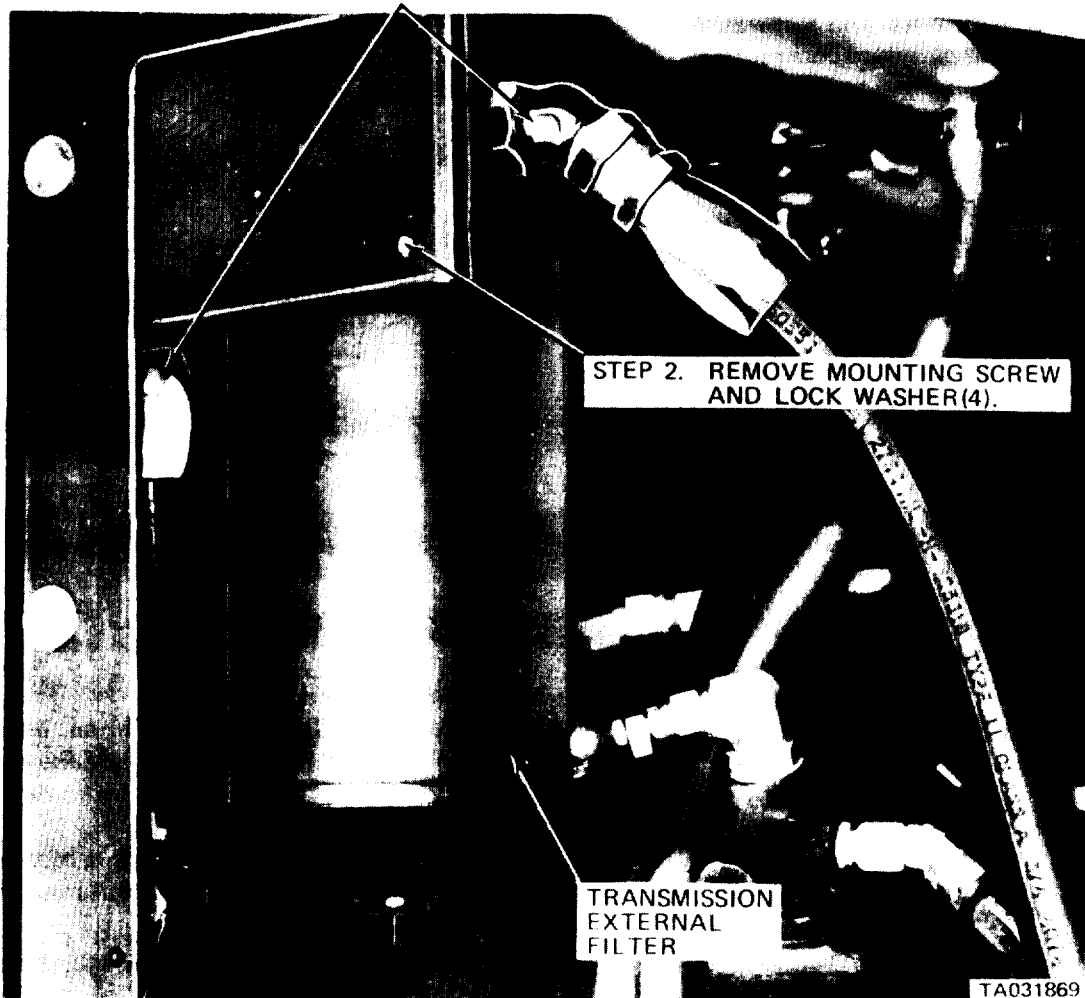

Figure 4-34. Transmission external filter, removal and installation.

4-55. Transmission Oil Level Check Plug

a. *Location.* Refer to figure 4-35.

b. *Service.* Refer to LO 10-3930-242-12-1 and -2.

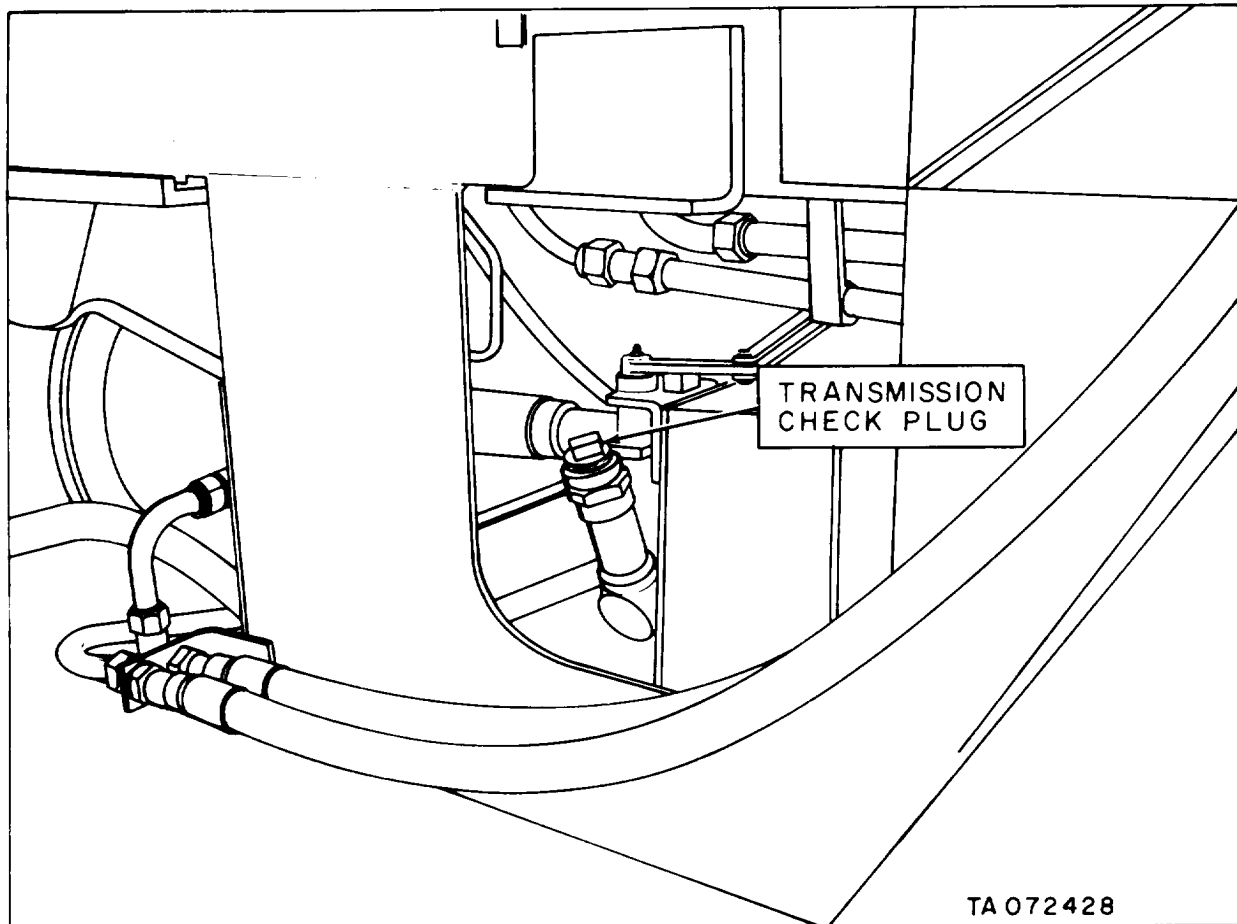

Figure 4-35. Transmission oil level check plug.

NOTE

Refer to current lubrication order for maintenance instructions for internal oil filter screen.

4-56. Transmission Linkage

a. *Inspect.* Check all linkage between operator's controls and transmission frequently. Remove console panel cover (fig. 4-31) and inspect the linkage for proper lubrication, cleanliness, wear, and damage.

(1) *Range Selector Linkage (low, med, high).* Make sure operator's controls (fig. 2-1) are positioned to correspond exactly with the detent positions of range selector valve.

(2) *Forward and Reverse Linkage.* Make sure operator's controls (fig. 2-1) correspond exactly with valve selector detents.

b. *Repair.* If (1) or (2) above are out of adjustment or need repair, report to direct support maintenance.

Section XIII. MAINTENANCE OF PROPELLER SHAFT

WARNING

Drycleaning solvent, P-D-680, used to clean parts is potentially dangerous to personnel and property. Do not use near open flame or excessive heat. Flash point of solvent is 138°F.

4-57. Propeller Shaft Yoke Flange

a. *Inspection.* Inspect propeller shafts and yoke flange for cracks, breaks, broken welds, or other damage.

b. *Service.* Service propeller shafts and yoke flanges in accordance with current lubrication order.

Section XIV. MAINTENANCE OF BRAKES

WARNING

Drycleaning solvent, P-D-680, used to clean parts is potentially dangerous to personnel and property. Do not use near open flame or excessive heat. Flash point of solvent is 138°F.

4-58. General

This section contains information for organizational maintenance of the brakes.

4-59. Service Brakes

a. General. The service brakes are expander tube type, hydraulically operated. Pressure is supplied by an engine driven hydraulic pump and application is controlled by an applicator valve located under the operator's floor plate. The brake adjustment is accomplished automatically by slack adjusters (fig. 4-37) located in the hydraulic lines between the applicator valve and the wheel brake assemblies. There is no manual adjustment. If a malfunction occurs which cannot be corrected by the bleeding process, report to direct support maintenance. Do not attempt to repair a slack adjuster, replace it. Lining wear can be detected by observing the arc of the brake lining retract springs. Retract springs are visible on the inboard side of the brake assembly, just below the outer circumference of the backing plate. Flattened springs (with the brakes off) indicate need for lining replacement. When the lining is in good condition, the springs will form a shallow arc. Check brake fluid for air after the first shift of operation.

b. Straight Hydraulic Brake System Bleeding Procedure.

- (1) Fill the reservoir with hydraulic oil (OE 10).

NOTE

Reservoir must be free of dirt. A screen should be provided in the reservoir to keep out foreign particles.

- (2) While engine is idling, open each bleeder valve (located on top of automatic slack adjuster fig. 4-37) and depress brake pedal until oil flows free of air. Close the bleed valves.

- (3) Apply brakes and hold pedal down for at least 10 seconds. Repeat this three times, allowing 30 seconds between applications.

- (4) Release the brakes and open all four bleeder valves. Bleed fluid from the brakes until flow stops and then close the bleeder valve.

- (5) Repeat (3) and (4) above until no air can be detected escaping from the fluid.

- (6) Repeat the entire bleeding procedure if the brakes show any evidence of dragging or overheating during the first few hours of operation.

NOTE

Brake lines should be checked for air after the first shift of operation. If brakes do not release properly after application, replace hydraulic tank filter. A clogged or restricted filter will prevent the oil from returning to the tank and therefore will not allow the brakes to release.

4-60. Emergency Brake Cable and Lever

a. Removal. Refer to figure 4-36 and remove the emergency brake cable and lever.

b. Cleaning and Inspection.

- (1) Clean the emergency brake cable and lever with drycleaning solvent (item 1, App F), and dry thoroughly.

- (2) Inspect the cable for broken wires and kinks. Inspect emergency brake lever and mounting brackets for cracks, breaks, and damaged parts. Replace all defective parts.

c. Installation. Refer to figure 4-36 and install emergency brake cable and lever.

d. Adjustment.

- (1) Release emergency brake.

- (2) Refer to figure 4-36 and remove yoke pin and cotter pin.

- (3) Turn yoke clockwise to tighten brake and counterclockwise to loosen brake.

- (4) Replace yoke pin and cotter pin.

- (5) Minor adjustment is accomplished by turning the knurled adjusting knob which is located at the top of the brake lever. Turn clockwise to tighten; counterclockwise to loosen.

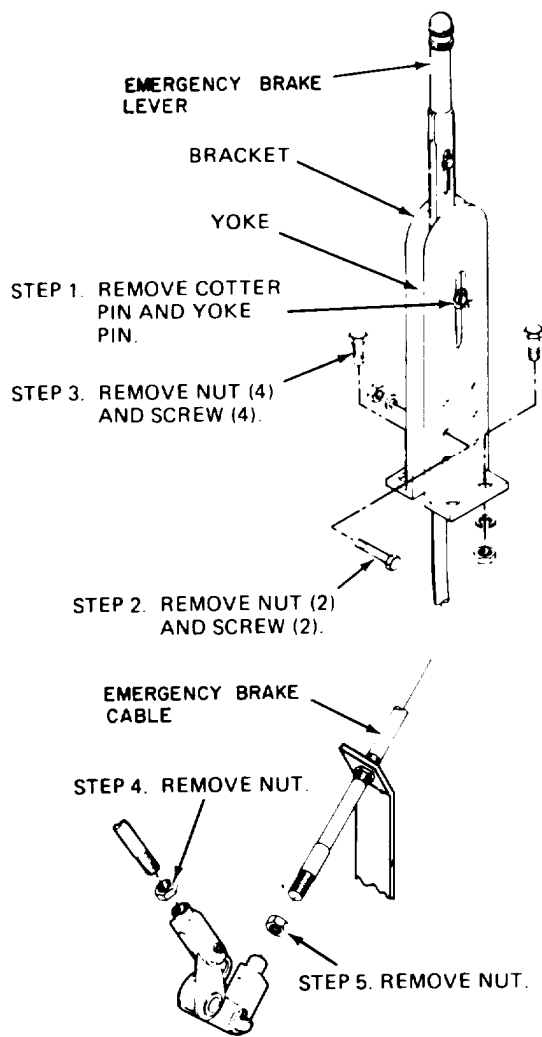

TA072400

Figure 4-36. Emergency brake cable and lever, removal and installation.

4-61. Slack Adjusters and Lines

a. Removal Refer to figure 4-37 for location of slack adjusters and remove as follows:

(1) Tag and disconnect two hydraulic lines to each slack adjuster.

(2) Cap all lines when disconnected to prevent foreign material from entering the brake system.

(3) Remove two screws, nuts, and lockwashers attaching each slack adjuster to the main frame. Remove the four slack adjusters.

b. Cleaning and Inspection

(1) Clean slack adjuster with an approved cleaning solvent and dry thoroughly.

(2) Inspect for corrosion, cracks, and loose connections. Check hoses for cuts and deterioration.

c. Installation. Refer to figure 4-37 and install the slack adjusters as follows:

(1) Use two screws, nuts, and lockwashers to mount each of the four slack adjusters to the main frame.

(2) Reconnect two hydraulic lines to each of the slack adjusters.

d. Bleeding. After installation of slack adjusters refer to paragraph 4-59b and bleed the hydraulic brake system.

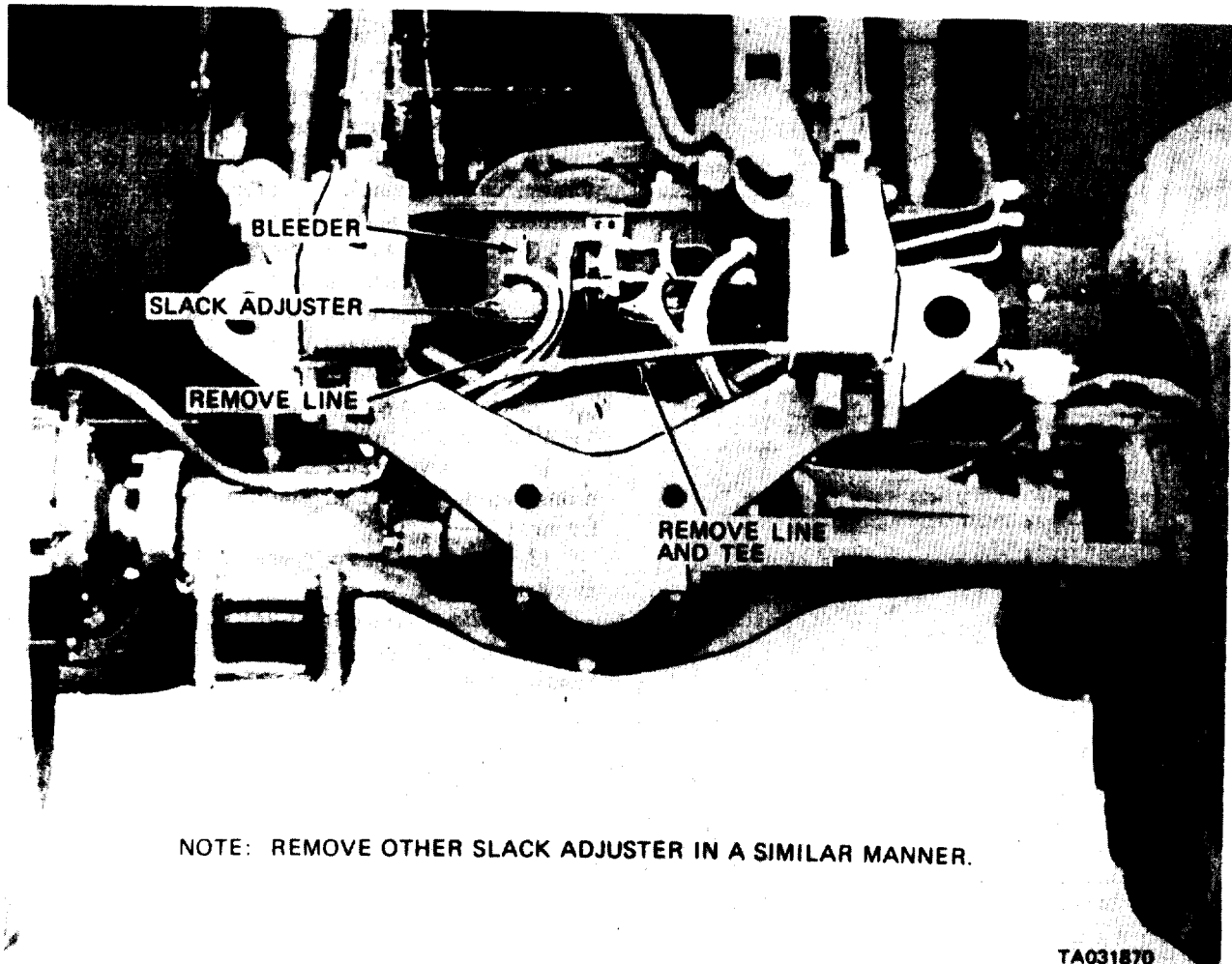

Figure 4-37. Slack adjusters and lines, removal and installation.

4-62. Brake Accumulator (figure 4-38)

a. *General.* The accumulator is provided to store energy for a limited number of brake applications. The accumulator system provides pressure for the brake system even when the engine is not operating. The accumulator is provided with a free piston and

is charged with dry nitrogen at approximately 275 psi. For access to the accumulator cylinder, remove the forward panels under the rear fenders.

b. *Inspection.* Inspect the accumulator for loose or corroded fittings or other damage.

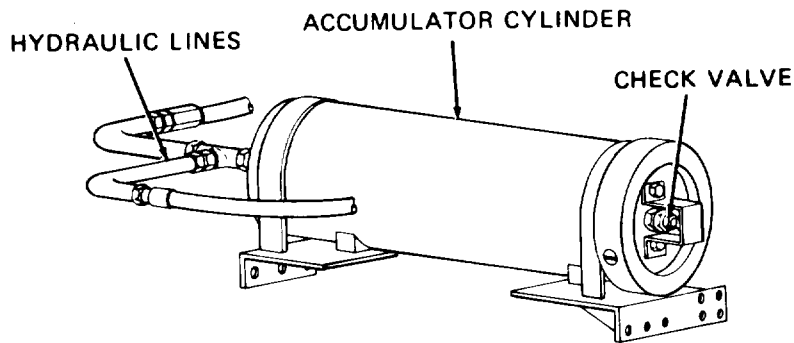

TA031872

Figure 4-38. Brake accumulator.

Section XV. MAINTENANCE OF WHEELS

WARNING

Drycleaning solvent, P-D-680, used to clean parts is potentially dangerous to personnel and property. Do not use near open flame or excessive heat. Flash point of solvent is 138°F.

4-63. Wheel Flanges, Wheels, and Tires

WARNING

Do not remove more than one tire at a time. Serious injury to personnel may result if vehicle falls.

a Removal. Refer to figure 4-39 and remove the wheel flanges, wheels, and tires.

b. Cleaning and Inspection.

(1) Clean the wheels and flanges with drycleaning solvent (item 1, App F) and dry thoroughly.

(2) Inspect the tires for cuts and deterioration. Check lockring, rim, wheel flanges, wheel, and nuts for cracks, breaks, and dents. Replace all defective parts.

WARNING

Insure lockring is properly seated before inflating tire. Serious injury to personnel may result should lockring snap out of seat.

c. Installation. Refer to figure 4-39 and install the wheel flanges, wheels and tires.

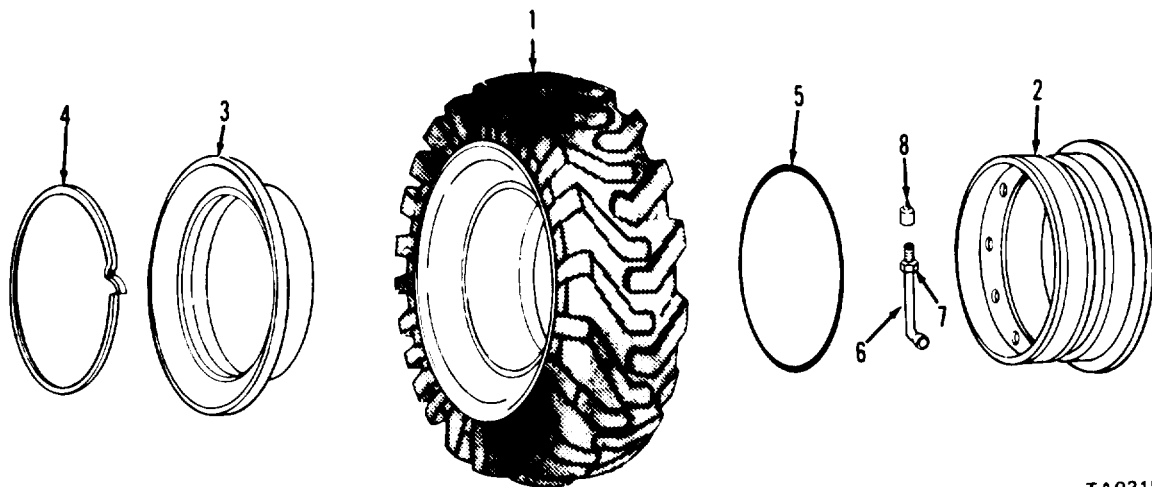

TA031873

- 1 Tire
- 2 Rim
- 3 Side ring
- 4 Lock ring
- 5 Packing
- 6 Valve stem
- 7 Valve stem adapter
- 8 Valve cap

Figure 4-39. Tire and wheel assembly.

Section XVI. MAINTENANCE OF STEERING SYSTEM

WARNING

Drycleaning solvent, P-D-680, used to clean parts is potentially dangerous to personnel and property. Do not use near open flame or excessive heat. Flash point of solvent is 138°F.

4-64. General

The steering system is hydraulic. Pressure is supplied by two hydraulic pumps mounted on the front and rear of torque converter housing. Normal operating pressure is 2,000 psi. Source of oil is the main hydraulic oil supply tank. The four wheel steering capability is controlled by a system of links located under the driver's compartment. The modes of steering are controlled by a three position hydraulic cylinder anchored on the pitman and acting upon the intermediate link. A valve, located in the link anchored on the rear cross shaft bellcrank and wheel forward end of the intermediate link, controls action of the rear wheel steering by hydraulic pressure.

CAUTION

Do not operate forklift truck with cockpit compartment doors open to prevent injury to personnel.

4-65. Tie Rods and Tie Rod Ends

a. Clean the tie rods and tire rod ends (fig. 4-40) with drycleaning solvent (item 1, App F) and Dry thoroughly.

b. Inspect the tie rods and tie rod ends for cracks, bends, and breaks. Inspect the pins for proper fit. Inspect nuts for stripped threads and proper fit. Report defective parts to your supervisor immediately.

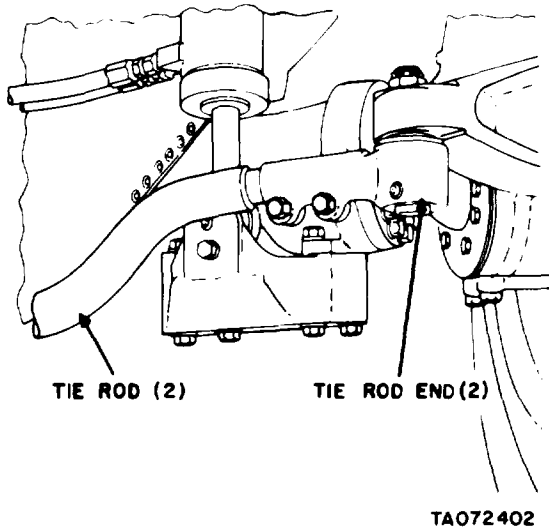

Figure 4-40. Tie rods and tie rod ends.

4-66. Hydraulic Steering Cylinders

NOTE

After removing hydraulic lines, be sure and cap lines and use plug caps on cylinders to keep out foreign objects.

a. *Cleaning.* Clean the steering cylinders with drycleaning solvent (item 1, App F) and dry thoroughly.

b. *Inspection.* Inspect the steering cylinder pins for correct fit. Check mounting and cylinder for cracks and damage. Check hydraulic lines for bends and nicks. Check line fittings for leaks and cracked nuts. Replace defective parts.

4-67. Drag Link Inspection

Inspect the drag link (fig. 4-41) for binding, breaks, or bends. Check mounting hardware for security. Replace a defective drag link.

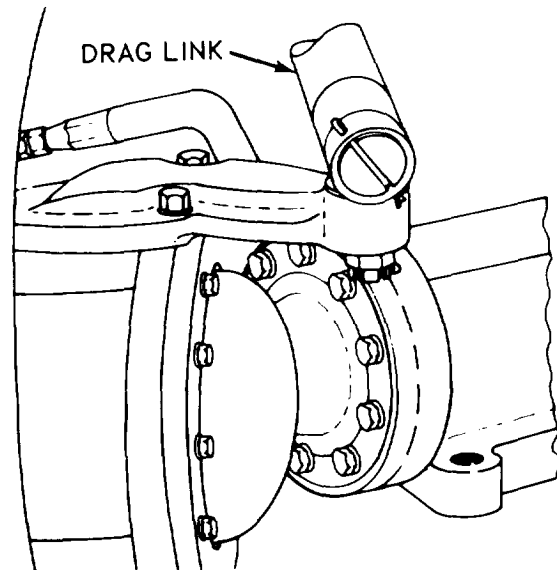

Figure 4-41. Drag link.

Section XVII. MAINTENANCE OF HOOD AND BODY**4-68. Roll Over Protective Structure (ROPS)***a. Removal*

(1) Remove floodlight (para 4-42).

(2) Refer to figure 4-42 and remove nine screws (1) and clips (2) to remove floodlight wire (3) from the ROPS.

(3) Remove two screws (4) and lockwashers (5) holding bottom of the ROPS to attachment structure (figure 4-42).

(4) Attach a hoisting device to lift ROPS. Remove two nuts (6), bolts (7), and washers (8) holding the ROPS to vehicle frame. Lift the ROPS (9) clear of vehicle and remove.

b. Inspection. Inspect the ROPS for cracks, breaks, or other damage. Inspect mounting hardware for wear, cracks, or breaks. Replace defective parts.

c. Installation.

(1) Use a suitable hoisting device to lift the ROPS (9) into place.

(2) Install two lockwashers (5) and screws (4) to pull the ROPS into position in attachment structure.

(3) Install nine screws (1) and clips (2) and attach floodlight wire (3) to the ROPS.

(4) Install floodlight (para 4-41).

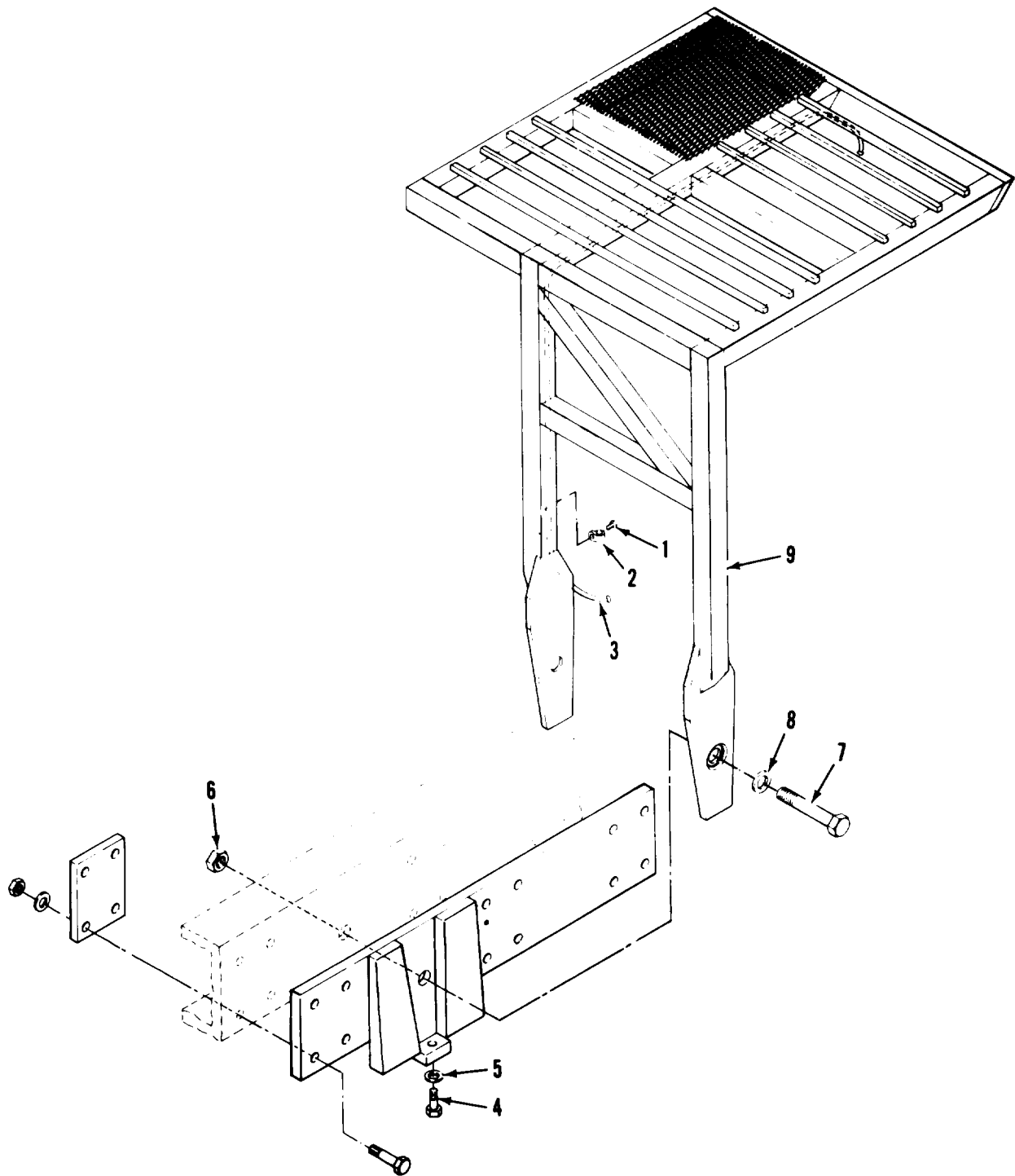

TA072404

- | | |
|--------------|----------|
| 1 Screw | 6 Nut |
| 2 Clip | 7 Bolt |
| 3 Wire | 8 Washer |
| 4 Screw | 9 ROPS |
| 5 Lockwasher | |

Figure 4-42. Roll overprotective structure (ROPS), removal and installation.

4-69. Seat*a Removal.*

(1) Refer to figure 4-43 for removal and installation of the seat for Army Models MHE 200 and MHE 202 forklift trucks.

(2) Refer to figure 4-44 for removal and installation of the seat for Army Model MHE 222 forklift truck.

WARNING

Drycleaning solvent, P-D-680, used to clean parts is potentially dangerous to personnel and property. Do not use near open flame or excessive heat. Flash point of solvent is 138°F.

b. Cleaning and Inspection.

(1) *Clean* controls and mounting hardware with drycleaning solvent (item 1, App F) and dry thoroughly.

(2) Inspect mounting hardware for damage.

Replace all defective parts.

(c) *Adjustment for Army Models MHE 200 and 202.*

(1) Turn handle clockwise to raise the seat and counterclockwise to lower.

(2) To release all pressure on shock absorbers, push down on release lever. Release lever will automatically reset.

(3) Turn tension handle clockwise to increase firmness of ride and counterclockwise to decrease.

(4) To move seat forward or back pull forward on handle at bottom of seat.

d. *Adjustment for Army Model MHE 222.*

(1) Move the seat adjustment handle inward to release the lock and move the seat.

(2) Move seat to desired position,

(3) Release the handle. This will automatically reposition the locking mechanism.

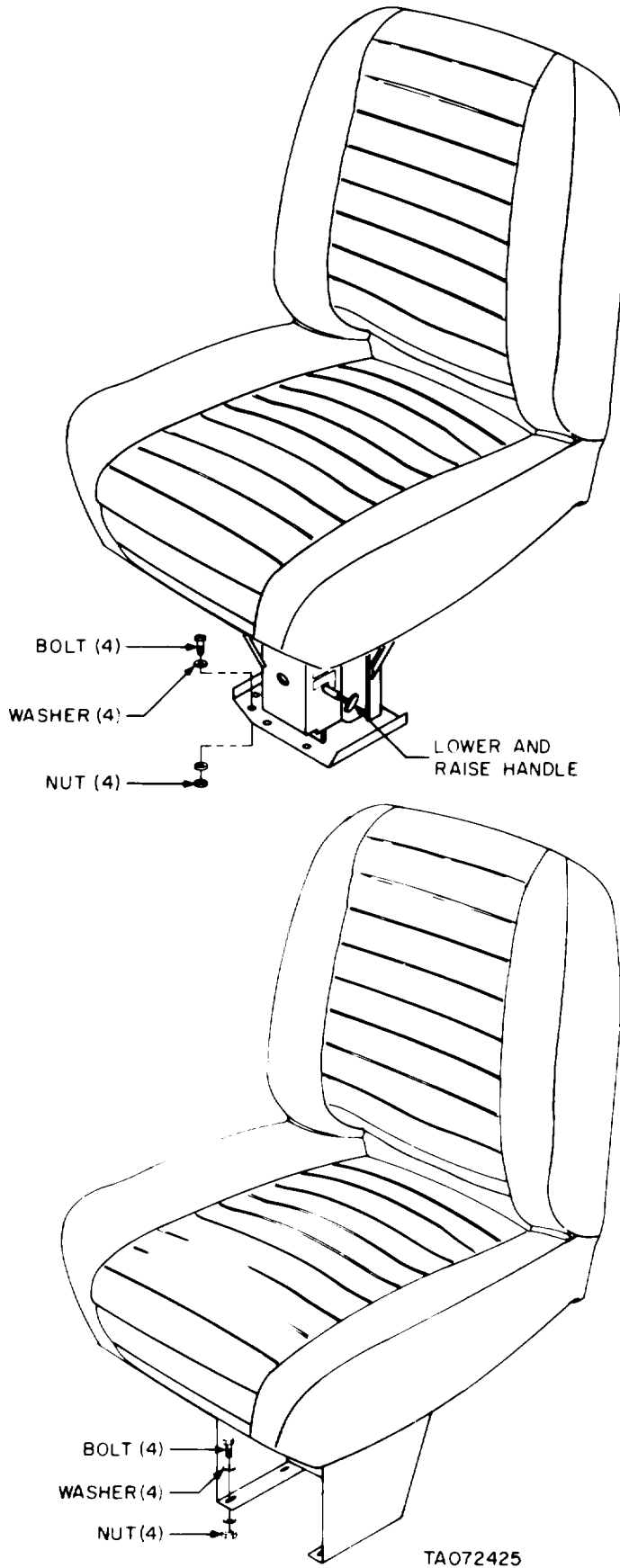
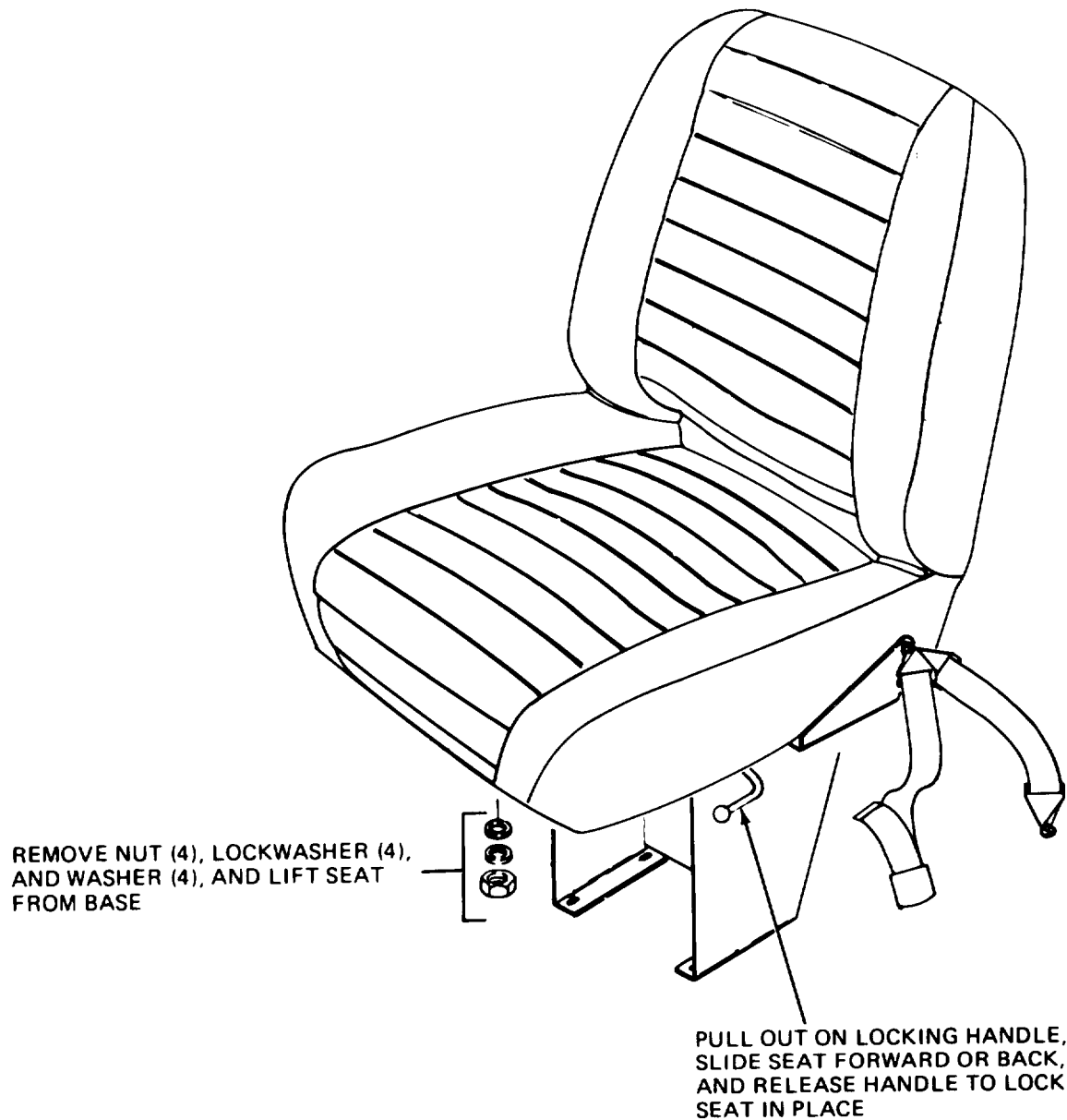

Figure 4-43. Seat removal adjustment, and installation. (Army models MHE 200 and MHE 202).



TA031884

Figure 4-44. Seat removal, adjustment, and installation. (Army model MHE 222).

4-70. Counterweight and Pintle Hook.

a. Removal. Refer to figure 4-45 and remove the counterweight and pintle.

b. Inspection. Inspect the pintle hook for proper locking operation, breaks, and cracks. Check all

mounting hardware for corrosion, cracks, and breaks. Replace defective parts.

c. Installation. Refer to figure 4-45 and install the counterweight and pintle hook.

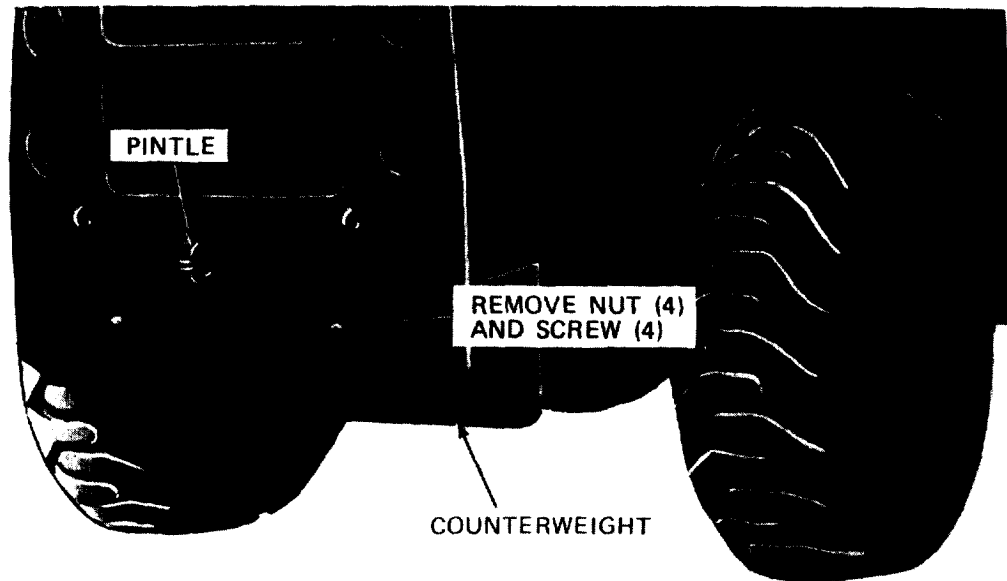

Figure 4-45. Counterweight and pintle hook, removal and installation.

Section XVIII. MAINTENANCE OF HYDRAULIC LIFT, PUMP, AND TUBING

CAUTION

When removing any hydraulic hoses and lines, cap all openings to prevent foreign material from entering system, causing serious damage to the system.

NOTE

Late model rough terrain forklift trucks are equipped with a filter contaminator indicator. This indicator is mounted on the top of the reservoir. Its purpose is to signal when the main hydraulic oil filter is in "by-pass" and is no longer serviceable.

4-71. Hydraulic Oscillator Cylinder

a. Cleaning. Clean the cylinder with drycleaning solvent (item 1, App F).

b. Inspection. Inspect for cracks, breaks, excessive wear, or loose or missing hardware. Inspect the hoses for deterioration and cuts. Replace all defective parts.

1-72. Tilt Cylinder

Inspect the cylinder piston end for wear. Inspect cylinder for cracks or leaks. If defective, report to direct support maintenance.

4-73. Fork Carriage

a. Removal. Refer to figure 4-46 and remove the fork carriage.

b. Cleaning and Inspection.

(1) Clean the carriage with drycleaning solvent (item 1, App F).

(2) Inspect the fork carriage for breaks or cracks in the welding. Inspect pins for wear. Replace all defective mounting hardware.

c. Installation. Refer to figure 4-46 and install the fork carriage.

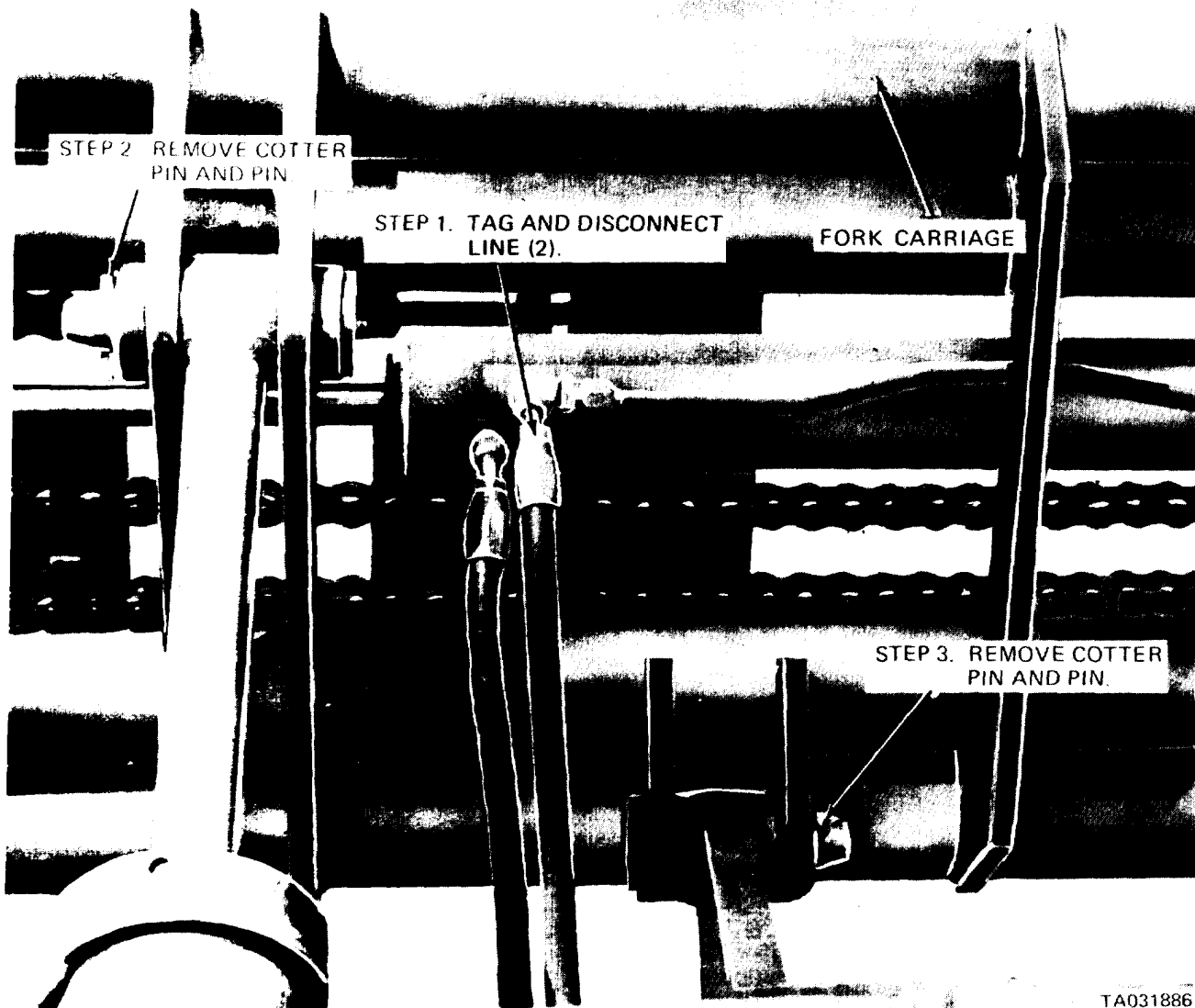

TA031886

Figure 4-46. Fork carriage, removal and installation.

4-74. Side Shift Roller Chain, Cylinder, and Forks

a. Removal.

(1) Block the carriage on 2 by 4 inch blocks so forks can be shifted manually. Loosen hoses slowly, allowing pressure to decrease.

(2) Refer to figure 4-47 and remove the side shift roller chain, cylinder, and forks.

b. Cleaning and Inspection.

(1) Clean the roller chain, cylinder, and forks with drycleaning solvent (item 1, App F).

(2) Inspect the chain for kinks, and broken or cracked links. Inspect cylinder for leaks. Replace all defective parts.

c. Installation. Refer to figure 4-47 and install the side shift roller chain, cylinder, and forks.

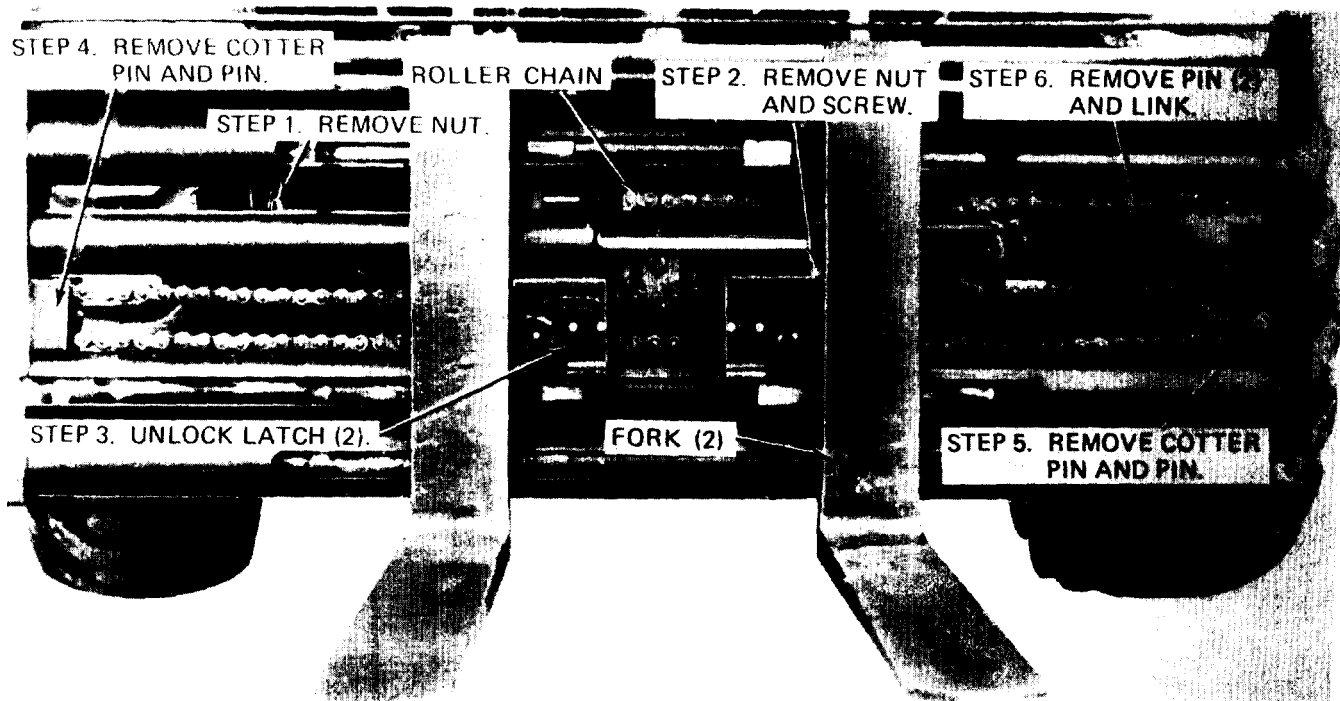

NOTE: REMOVE FORK (2) AND CYLINDER OUT OF LEFT FRONT OF CARRIAGE.

TA031987

Figure 4-47. Side shift roller chain, cylinder, and forks, removal and installation.

4-75. Hydraulic Lift Cylinder

WARNING

Before commencing work on the hydraulic lift cylinder, use supports provided to block up mast. Personal injury or death may result from a falling mast.

Inspect the hydraulic lift cylinders for cracks, breaks, worn pins, and leaks. Report defective cylinders to direct support maintenance.

4-76. Contamination Indicator

The purpose of the contamination indicator is to signal when the main hydraulic oil filter is in "by-pass" and is no longer serviceable.

NOTE

As the result of an engineering change, the hydraulic reservoir on late model

rough terrain forklift trucks are equipped with a filter contamination indicator mounted on the top of the reservoir and in place of the former filter cover plate. The purpose of the contamination indicator is to signal when the main hydraulic oil filter is in "by-pass" and is no longer serviceable.

- a. *Removal.* Remove the contamination indicator as illustrated in figure 4-48.
- b. *Cleaning and Inspection.*
 - (1) Clean all metal parts.
 - (2) Inspect mounting hardware for damage or excessive wear.
- c. *Repair.* Repair all defective parts.
- d. *Installation.* Install the contamination indicator as illustrated in figure 4-48.

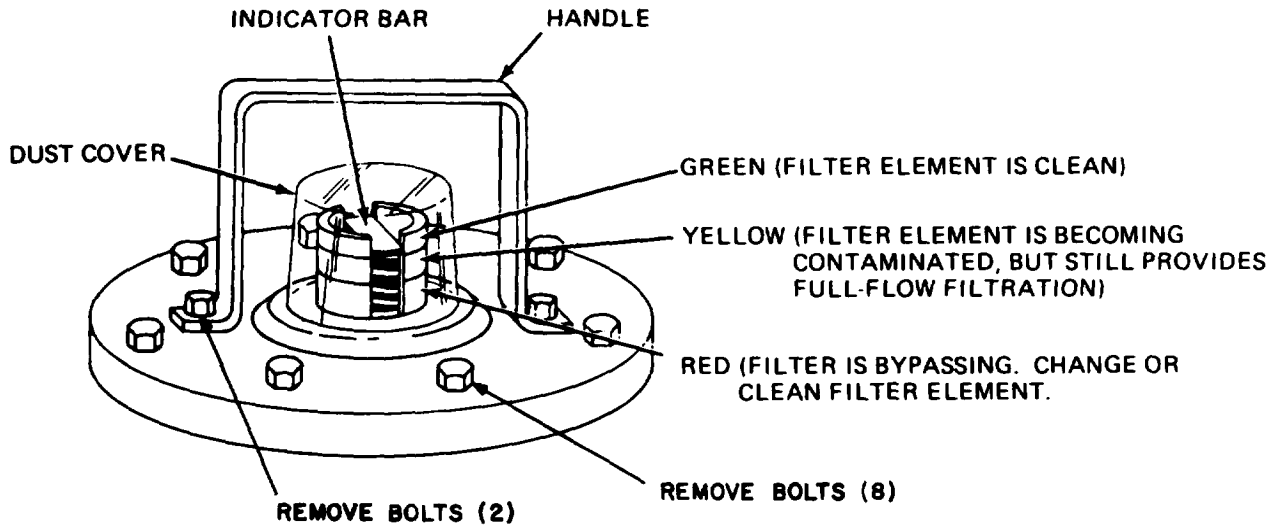

TA072405

Figure 4-48. Contamination indicator.

4-77. Hydraulic Hoses

a. General. Hydraulic truck are equipped with reusable fittings. The hose is available in bulk and may be cut to length as required. Higher pressure hose is constructed with a 2-wire braid. Hose size is determined by a dash number on the hose or fittings. For example, a -12, on the hose or fitting indicates size in sixteenths of

an inch, such as a -12, indicates 12/16 or 3/4 inch. refer to figure 4-49 for installation of hoses and fittings.

b. Positioning of Hoses. Make sure that the hoses on the hydraulic cylinders, such as the tilt cylinder, extension cylinder, and lift cylinder, are positioned in such a manner that the hose will not chafe or be cut during operation of the unit.

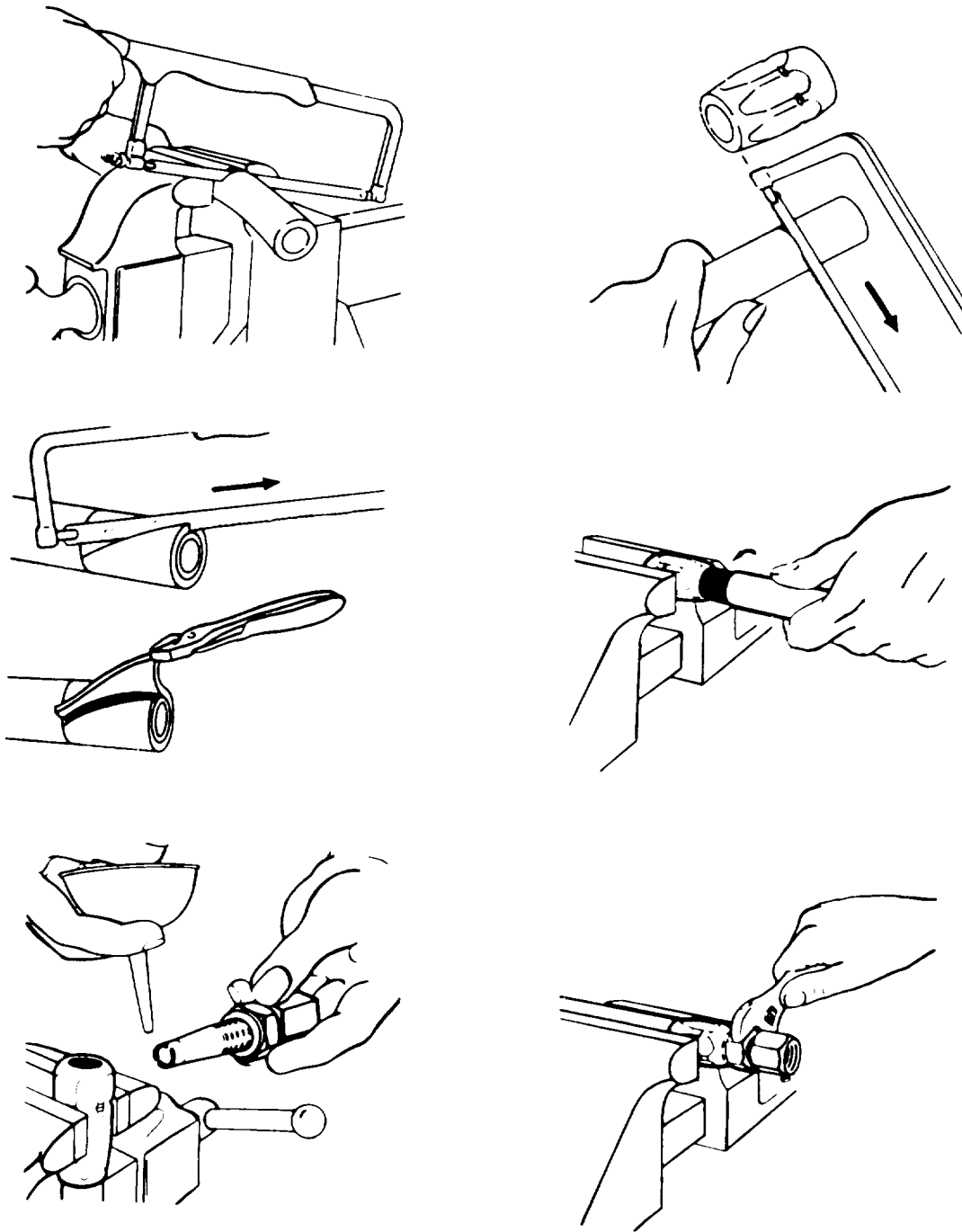

Figure 4-49. Installing high pressure hose fittings.

TA031881

APPENDIX A

REFERENCES

A-1. Fire Protection and Safety

TB 5-4200-200-100

Hand Portable Fire Extinguishers Approved for Army Users.

A-2. Lubrication

LO 10-3930-242-12

Truck, Lift, Fork, Diesel Engine, Pneumatic Tired Wheels, Rough Terrain; 6,000 lb Capacity, 24 Inch Load Center (Anthony Model MLT-6), (Army Model MHE 200), (Chrysler Model MLT-6CH), (Army Model MHE 202), (Athey Model ARTFT-6), (Army Model MHE 222).

A-3. Cleaning

TM 9-247

Materials Used for Cleaning, Preserving, Abrading, and Cementing Ordnance Materiel and Related Materials Including Chemicals.

SB 725-7930-1

Issue of Supplies and Equipment, Engineering Practices of CONUS and Overseas Installation Requirements for Hard and Soft Water Cleaning Compounds.

A-4. Maintenance

FM 29-2

Organizational Maintenance Operations.

TB 750-651

Use of Antifreeze Solutions and Cleaning Compounds in Engine Cooling Systems.

TM 9-2610-200-24

Organizational, Direct Support and General Care, Maintenance and Repair of Pneumatic Tires and Inner Tubes.

TM 9-6140-200-14

operator's, Organizational, Direct Support, and General Support Maintenance Manual for Lead-Acid Storage Batteries 4HN, 24 Volt (6140-059-3528) MS75047-1, 2HN, 12 Volt (6140-00-057-2553) MS35000-1, 6TN, 12 Volt (6140-00-057-2554) MS35000-3.

TM 10-3930-242-20P

Organizational Maintenance Repair Parts and Special Tools List: Truck, Lift, Fork, Diesel Engine, Pneumatic Tired Wheels, Rough Terrain; 6,000 lb Capacity, 24 Inch Load Center (Athey Model ARTFT-6, Army Model MHE-222 (FSN 3930-419-5744).

DA Pam 738-750

The Army Maintenance Management System (TAMMS).

A-5. Shipment and Storage

TM 740-90-1

Administrative Storage of Equipment.

A-6. Demolition

TM 750-244-3

Procedures for Destruction of Equipment to Prevent Enemy Use.

A-7. Operation

TM 5-331B

Utilization of Engineer Construction Equipment: Volume B-Lifting, Loading, and Hauling Equipment.

APPENDIX B
COMPONENTS OF END ITEM LIST

There are none authorized.

APPENDIX C

ADDITIONAL AUTHORIZATION LIST

SECTION I. INTRODUCTION

C-1. Scope

This appendix lists additional items you are authorized for the support of the rough terrain fork lift truck.

C-2. General

This list identifies items that do not have to accompany the rough terrain fork lift truck and that do not have to be turned in with it. These items are all

authorized to you by CTA, MTOE, TDA, or JTA.

C-3. Explanation of Listing

National stock numbers, descriptions, and quantities are provided to help you identify and request the additional items you require to support this equipment. The items are listed in alphabetical sequence by item name under the type document (i.e., CTA, MTOE, TDA, or JTA) which authorizes the item to you.

Section II. ADDITIONAL AUTHORIZATION LIST

(1) National Stock Number	(2) Description FSCM & Part Number	(3) U/M	(4) Qty Auth
<u>MTOE AUTHORIZED ITEMS</u>			
4910-00-138-1819	Constrictor. bead expander (31989) TC28	EA	1
4910-00-204-2644	Gage, tire pressure (83148) GGG91	EA	1

APPENDIX D

MAINTENANCE ALLOCATION CHART

Section I. INTRODUCTION

D-1. General

a. This section provides a general explanation of all maintenance and repair functions authorized at various maintenance categories.

b. The Maintenance Allocation Chart (MAC) in section II designates overall authority and responsibility for the performance of maintenance functions on the identified end item or component. The application of the maintenance functions to the end item or component will be consistent with the capacities and capabilities of the designated maintenance categories.

c. Section III lists the tools and test equipment (both special tools and common tool sets) required for each maintenance function as referenced from section II.

d. Section IV contains supplemental instructions and explanatory notes for a particular maintenance function.

D-2. Maintenance Functions. Maintenance functions will be limited to and defined as follows:

a. *Inspect*. To determine the serviceability of an item by comparing its physical, mechanical, and/or electrical characteristics with established standards through examination (e.g., by sight, sound, or feel).

b. *Test*. To verify serviceability by measuring the mechanical, pneumatic, hydraulic, or electrical characteristics of an item and comparing those characteristics with prescribed standards.

c. *Service*. Operations required periodically to keep an item in proper operating condition, i.e., to clean (including decontaminate, when required), to preserve, to drain, to paint, or to replenish fuel, lubricants, chemical fluids, or gases.

d. *Adjust*. To maintain or regulate, within prescribed limits, by bringing into proper or exact position, or by setting the operating characteristics to specified parameters.

e. *Aline*. To adjust specified variable elements of an item to bring about optimum or desired performance.

f. *Calibrate*. To determine and cause corrections to be made or to be adjusted on instruments or test, measuring, and diagnostic equipments used in precision measurement. Consists of comparisons of two instruments, one of which is a certified standard of known accuracy, to detect and adjust any discrepancy in the accuracy of the instrument being compared.

g. *Remove/Install*. To remove and install the same item when required to perform service or other maintenance functions. Install may be the act of emplacing, seating, or fixing into position a space, repair part, or module (component or assembly) in a manner to allow the proper functioning of an equipment or system.

h. *Replace*. To remove an unserviceable item and install a serviceable counterpart in its place. "Replace" is authorized by the MAC and is shown as the third position of the SMR code.

i. *Repair*. The application of maintenance service¹, including fault location/troubleshooting², removal/installation, disassemble/assembly³ procedures, and maintenance actions⁴ to identify troubles and restore serviceability to an item by correcting specific damage, fault, malfunction, or failure in a part, subassembly, module (component or assembly), end item, or system.

j. *Overhaul*. That maintenance effort (service/action) prescribed to restore an item to a completely serviceable/operational condition as required by maintenance standards in appropriate technical publication (i.e., DMWR), Overhaul is normally the highest degree of maintenance performed by the Army. Overhaul does not normally return an item to like-new condition.

¹Service-inspect, test, service, adjust, aline, calibrate, and/or replace.

²Fault locating/troubleshooting – The process of investigating and detecting the cause of equipment malfunctioning; the act of isolating a fault within a system or unit under test (UUT).

³Disassemble/assembly – encompasses the step-by-step taking apart (or breakdown) of a spare/functional group coded item to the level of its least component identified as maintenance significant (i.e., assigned an SMR code) for the category of maintenance under consideration.

Action –welding, grinding, reiveting, straightening, facing, remachining, and/or resurfacing.

k. Rebuild. Consists of those services/actions necessary for the restoration of unserviceable equipment to a like-new condition in accordance with original manufacturing standards. Rebuild is the highest degree of materiel maintenance applied to Army equipment. The rebuild operation includes the act of returning to zero those age measurements (hours/miles, etc.) considered in classifying Army equipment/components.

D-3. Explanation of Columns in the MAC, Section II

a. Column 1, Group Number. Column 1 lists functional group code numbers, the purpose of which is to identify maintenance significant components, assemblies, subassemblies, and modules with the next higher assembly. End item group number shall be "00".

b. Column 2, Component/Assembly. Column 2 contains the names of components, assemblies, subassemblies, and modules for which maintenance is authorized.

c. Column 3, Maintenance Function. Column 3 lists the function to be performed on the item listed in Column 2. (For detailed explanation of these functions, see paragraph D-2).

d. Column 4, Maintenance Category. Column 4 specifies, by the listing of a worktime figure in the appropriate subcolumns, the category of maintenance authorized to perform the function listed in column 3. This figure represents the active time required to perform that maintenance function at the indicated category of maintenance. If the number or complexity of the task within the listed maintenance function vary at different maintenance categories, appropriate worktime figures will be shown for each category. The worktime figure represents the average time required to restore an item (assembly, subassembly, component, module, end item, or system) to a serviceable condition under typical field operating conditions. This time includes preparation time (including any necessary disassemble y/assembly time), troubleshooting/fault location time, and quality assurance/quality control time in addition to the time required to perform specific tasks identified for the maintenance functions authorized in the maintenance allocation

chart. The symbol designations for the various maintenance categories are as follows:

- C – Operator or Crew
- O – organizational Maintenance
- F – Direct Support Maintenance
- H – General Support Maintenance
- D – Depot Maintenance

e. Column 5, Tools and Equipment. Column 5 specifies by code, those common tool sets (not individual tools) and special tools, TMDE, and support equipment required to perform the designated function.

f. Column 6, Remarks. This column shall, when applicable, contain a letter code, in alphabetical order, which shall be keyed to the remarks contained in Section IV.

D-4. Explanation of Columns in Tool and Test Equipment Requirements, Section III

a. Column 1, Reference Code. The tool and test equipment reference code correlates with a code used in the MAC, Section II, Column 5.

b. Column 2, Maintenance Category. The lowest category of maintenance authorized to use the tool or test equipment.

c. Column 3, Nomenclature. Name or identification of the tool or test equipment.

d. Column 4, National Stock Number. The National stock number of the tool or test equipment.

e. Column 5, Tool Number. The manufacturer's part number.

D-5. Explanation of Columns in Remarks, Section IV

a. Column 1, Reference Code. The code recorded in column 6, Section II.

b. Column 2, Remarks. This column lists information pertinent to the maintenance function being performed as indicated in the MAC, Section II.

Section II. MAINTENANCE ALLOCATION CHART

(1) Group number	(2) Component/Assembly	(3) Maintenance function	(4) Maintenance category					(5) Tools and eqpt	(6) Remarks
			C	O	F	H	D		
01	ENGINE								
0100	Engine Assembly	Inspect Service Adjust Replace	0.1 0.5	0.2 1.5 0.4	8.0			1,2,3 1,2,3 1,2,3 5 thru 8 10,12	
		Repair				2.0		5 thru 8 10,12	
		Overhaul					0.0	5 thru 8 10,12	
	Mounts, Engine	Inspect Replace			0.1 2.0			3,7 3,7	
0101	Crankcase, Block, Cylinder Head Head Assembly	Inspect Replace Repair Overhaul			0.1 1.5 2.4			3,7 3,7 3,5,7 3,5,7	
0102	Crankshaft	Inspect Replace Repair				0.3 20.0		3,7 3,5,7 3,5,7	
							8.0		
0103	Flywheel Assembly Flywheel	Inspect Replace Repair		0.2	8.0 2.0			2,3 3,5,7,9 3,5,7,9	
	Flywheel Housing	Inspect Replace		0.2	8.0			2,3	
0101	Pistons, Connecting Rods Connecting Rods	Inspect Replace Repair				0.2 4.0 4.0		3,7 3,5,7,9 3,5,7,9	
	Pistons	Replace				4.0		2,3,8	
0105	Valves, Camshafts, and Timing Systems Camshaft and Gear Train	Inspect Replace			0.2		20.0	3,7 3,5,7,9	
	Rocker Arm and Related Parts	Inspect Replace Repair			0.2 1.0 1.0			3,7 3,5,7,9 3,5,7,9	
0106	Engine Lubrication System Pump, Oil and Related Parts Element, Oil Filter	Replace Repair Service Replace		0.5 0.5			4.0 3.0	3,7,9 3,7,9 2,3 2,3	
	Cooler, Oil	Inspect Test Replace			0.1 1.0 0.5			3,7 3,7 3,7	
	Breather, Crankcase Dip stick, and Filler Pipe	Service Replace		0.1 0.1				2,3 2,3	

MAINTENANCE ALLOCATION CHART - CONTINUED

(1) Group number	(2) Component/ Assembly	(3) Maintenance function	(4) Maintenance category					(5) Tools and eqpt	(6) Remarks
			C	O	F	H	D		
01	ENGINE - CONTINUED								
0108	Manifolds Manifold, Exhaust	Inspect Replace	0.1	0.7				1,2,3	
03	FUEL SYSTEM								
0301	Fuel Injector	Inspect Test Replace Repair			0.5 3.0	1.0		7 3,6,7 6,7,8,9	
	Linkage, Injector	Inspect Adjust Replace Repair			0.1 0.5 1.0 1.5	3.0		6,7,8,9 7 7 6,7,8,9 6,7,8,9	
0302	Fuel Pumps Pump, Fuel	Inspect Replace Repair		0.3 1.0				2,3 2,3	
	Hoses, Lines and Fittings	Inspect Replace	0.1		2.0			3,7,8,9	
				0.5				1,2,3	
0304	Air Cleaner	Replace Repair		0.5 1.0				1,2,3 2,3	
	Element, Air Cleaner	Inspect Service Replace	0,1					2,3 2,3	
				0.3 0.1				2,3 2,3	
0305	Blower	Replace Repair			0.5			3,7,8,9 3,7,8,9	
	Housing Inlet	Inspect Replace		0.1 0.3		2.0		2,3 3,7,8,9	
0306	Tanks, Lines, Fittings Tank. Fuel	Inspect Service Replace	0.1 0.3						
		Repair			1.0 2.0			3,4,5,7, 9 3,4,5,7, 9	
0308	Engine Speed Governor and Controls Governor, Engine	Adjust Replace Repair			0.5 1.0 2.0			3,7 3,7,8,10 3,7,8,10	
0309	Fuel Filters Filter Assembly, Fuel and Water Separator	Service Replace Repair		0.7	1.5 1.5			2,3 2,3 2,3	
	Strainer Assembly, Fuel	Service Replace Repair		1.0 1.5 1.0				2,3 2,3 2,3	

MAINTENANCE ALLOCATION CHART - CONTINUED

(1) Group number	(2) Component/Assembly	(3) Maintenance function	(4) Maintenance category					(5) Tools and eqpt	(6) Remarks
			C	O	F	H	D		
03	FUEL SYSTEM – CONTINUED								
0309	Fuel Filters – Continued Filter Element, Strainer Assembly	Replace		0.5				2,3	
0311	Engine Starting Aids Starting Aid Assembly	Service Replace Repair		0.2 1.0 0.5				2,3 1,2,3 1,2,3	
0312	Accelerator, Throttle or Choke Controls Control, Throttle	Inspect Adjust Replace Repair	0.1	0.5 0.5 0.5				1,2,3 1,2,3 1,2,3	
04	EXHAUST SYSTEM								
0401	Muffler and Pipes	Inspect Replace	0.1	1.0				1,2,3	
05	COOLING SYSTEM								
0501	Radiator	Inspect Test Service Replace Repair	0.1 0.2	0.5	1.5 2.0			2,3 3,4,5,7, 9 3,4,5,7, 9	
0502	Shrouds	Replace		0.5				2,3	
0503	Water Manifold, Headers, Thermostats and Housing Gasket Thermostat and Housing Hoses, Clamps and Fittings	Inspect Replace Inspect Replace	0.1	0.1 0.5 0.3				3 3 3	
0504	water Pump	Inspect Replace Repair		0.1 1.0	1.5			3 3 7,10	
0505	Fan Assembly Guard, Fan Fan Pulley Assembly	Replace Inspect Replace Inspect Replace Repair		1.0 0.1 0.5 0.1 0.5 1.0				2,3 3 2,3 2,3 2,3	

MAINTENANCE ALLOCATION CHART - CONTINUED

(1) Group number	(2) Component/Assembly	(3) Maintenance function	(4) Maintenance category					(5) Tools and eqpt	(6) Remarks
			C	O	F	H	D		
05	COOLING SYSTEM - CONTINUED								
0505	Fan Assembly — Continued								
	Belt, Fan Drive and Tightener	Inspect Adjust Rcplace	0.1	0.1 0.5				2,3 2,3	
	Linkage, Fan Disconnect Control	Inspect Adjust Replace Repair		0.1 0.1 0.5 0.5				3 2,3 2,3 2,3	
06	ELECTRICAL SYSTEM								
0601	Gencrator	Inspect Test Replace Rcpair		0.1 0.5 0.5				3 2,3 2,3	
	Generator Drive Belt and Tightener	Inspect Adjust Replace	0.1		2.0			3,7,8 2,3 2,3	
0602	Generator Regulator	Inspect Test Replace		0.1 0.5 0.5				3 2,3 2,3	
0603	Starting Motor Starter	Inspect Test Replace Repair Replace		0.1 0.5 0.5				3 2,3 2,3	
	Relay (MHE-200 w/o ROPS, MHE-202 w/o ROPS, MHE-200 w/ROPS, MHE-202 w/ROPS)				2.0			3,7,8	
	Relay (MHE-222 w/o ROPS, MHE-222 w/ROPS)	Replace		0.5	0.5			2,3	
0607	Instrument or Ehgine Control Panel Panel, Control	Inspect Test Replace Repair	0.1					2,3 1,2,3 1,2,3	
	Gages, Switches and Indicator Lights	Inspect Test Replace	0.1					2,3 1,2,3	
	Switch, Rotary	Inspect Test Replace Repair	0.1	0.1 0.5				2,3 1,2,3 1,2,3	
0608	Miscellaneous Items Switches	Replace		0.5				1,2,3	

MAINTENANCE ALLOCATION CHART - CONTINUED

(1) Group number	(2) Component/Assembly	(3) Maintenance function	(4) Maintenance category					(5) Tools and eqpt	(6) Remarks
			C	O	F	H	D		
06	ELECTRICAL SYSTEM - CONTINUED								
0609	Lights	Inspect Test Replace Repair	0.1 0.1	0.5 0.5				2,3 2,3	
0610	Sending Units and Warning Switches Warning Switches	Inspect Test Replace	0.1	1.0 1.0				2 3,7,10	
0611	Horn	Test Replace	0.1	0.5				2,3	
0612	Batteries, Storage Batteries, Box, Holddown and Cables Connector, Slave Receptacle	Inspect Test Service Replace Inspect Test Replace Repair	0.1 0.3 0.1	0.3 1.0 0.1 0.5 0.5				2,3 2,3 2,3 2,3 2,3	
0613	Chassis Wiring Harness Lead, Electrical (MHE-200 W/ROPS, MHE-202 w/ROPS, MHE-222 w/ROPS)	Inspect Test Replace Repair Replace	0.2	1.0	1.0 1.0	1.0		2,3 3,7,10 3,7,10 3,7,10	
07	TRANSMISSION								
0705	Gear Shift Controls Controls, Transmission Linkage	Inspect Adjust Replace	0.1	1.5	0.2			3,7,9 3,7,9	
0708	Torquc Connverter Hoses, Lines and Fittings	Test Service Replace Overhaul Inspect Replace	0.1	0.1 0.5	0.2		8.0 8.0	3,7 2,3 3,7,9,12 1,2,3	
0710	Transmi.ssion Assembly (Hydraulic)	Test Service Replace Repair Overhaul		1.0	0.2 8.0	8.0	40.0	3,7 2,3 3,5,7,9 35,7,9	
0713	Intermediate Clutch	Test Replace		0.5		5.0		2,3 3,7,9	

MAINTENANCE ALLOCATION CHART - CONTINUED

(1) Group number	(2) Component/Assembly	(3) Maintenance function	(4) Maintenance category					(5) Tools and eqpt	(6) Remarks
			c	o	F	H	D		
07	TRANSMISSION - CONTINUED								
0714	Servo Unit Control Valve	Test Replace Repair		0.5	3.5	2.0		2,3 3,7,9 3,8,9	
0721	Coolers, Pumps, Motors Element, Oil Filter Valve, Pressure Regulator	Service Replace Test Adjust Replace Repair		0.5 1.0	0.2 0.5 1.0	2.0		3 2,3 3,7 3,7 3,7 3,8	
0725	Idler Gears	Replace				30		3,7	
08	TRANSFER ASSEMBLY								
0801	Power Transfer Assembly Housing Assembly, Power Take-Off	Replace Repair			1.0 2.0			2,3 2,3	
09	PROPELLER SHAFTS								
0900	Prepeller Shafts Shaft Assemblies Spider and Bearings	Inspect Replace Repair Service Replace		0.1	2.0 1.0			3 3,7 2,3 2,3 3,7	
10	FRONT AXLE								
1000	Front Axle Assembly	Inspect Service Replace Repair Overhaul		0.1 0.3	8.0	4.0	60	2,3 2,3 3,4,5,7, 9 3,4,5,7, 9	
1002	Differential Differential Lock, Cylinder Assembly	Service Replace Repair Overhaul Inspect Service Replace Repair	0.1	0.3 0.2 1.0	4.0 20		6.0 8.0	2,3 3,5,7,9 3,9,11 1,2,3 1,2,3 3,4,5,7, 9	

MAINTENANCE ALLOCATION CHART - CONTINUED

(1) Group number	(2) Component/Assembly	(3) Maintenance function	(4) Maintenance category					(5) Tools and eqpt	(6) Remarks
			C	O	F	H	D		
10	FRONT AXLE - CONTINUED								
1003	Planetary or Final Drive Drive, Planetary	Inspect		0.1				2,3	
		Service		0.3				2,3	
		Replace			2.0			3,5,7,9	
		Repair			2.0			3,5,7,9	
1004	Steering Mechanism Steering Spindle and Cylinder Steering Support	Replace			1.5			3,7,10	
		Replace			3.0			3,7,10	
11	REAR AXLE								
1100	Rear Axle Assembly	Inspect		0.1				2,3	
		Service		0.3				2,3	
		Replace			8.0			3,4,5,7,9	
		Repair				4.0		3,4,5,7,9	
	Overhaul					16.0	3,4,5,7,9		
1101	Housing, Housing Covers, Plugs, Rear Axle Housing Axle Housing	Inspect		0.1				2,3	
		Service		0.5				2,3	
		Replace			15.0			3,4,5,7,9	
		Repair			5.0			3,4,5,7,9	
1102	Differential	Service		0.3				2,3	
		Replace			4.0			3,4,5,7,9	
		Repair					6.0	3,4,5,7,9	
	Differential Lock	Overhaul					8.0	3,4,5,7,9	
		Inspect	0.1						
		Service		0.2				2,3	
		Replace			1.0			3,5,7,9	
	Repair			2.0			3,5,7,9		
1103	Planetary or Final Drive Drive, Planetary	Inspect		0.1				2,3	
		Service		0.3				2,3	
		Replace			2.0			3,5,7,9	
		Repair			2.0			3,5,7,9	
1104	Steering Mechanism Steering Spindle and Cylinder Steering Support	Replace			2.5			3,5,7,9	
		Replace			3.0			3,5,7,9	

MAINTENANCE ALLOCATION CHART - CONTINUED

(1) Group number	(2) Component/Assembly	(3) Maintenance function	(4) Maintenance category				(5) Tools end eqpt	(6) Remarks
			C	O	F	H		
12	BRAKES							
1201	Hand Brakes Parking Brake	Replace			1.5			3,7,9
		Repair			2.0			3,7,9
	Hand Brake Lever, Assembly	Replace		0.5				3,7,9
		Repair		1.0				3,7,9
	Hand Brake Link Assembly	Replace		1.0				3,7,9
		Repair		1.0				3,7,9
1202	Service Brake	Inspect		0.1				2,3
		Replace			16.0			3,7,9
		Repair				1.0		
	Brake Adjusters	Inspect		0.1				
		Replace		1.0				3,7,9
		Repair			2.0			
1204	Hydraulic Brake System Valve, Disconnect	Inspect		0.1				3
		Test			0.2			3,7
		Replace			1.0			3,7
	Valve, Brake	Replace		0.1				2,3
		Repair			1.0			3,7,9
	Accumulator, Brake	Inspect		0.1				3,7,9
		Service		1.0				3,1,13
		Replace		1.0				3,1
		Repair			1.5			3,1,13
1206	Mechanical Brake System Pedal and Linkage	Replace		1.0				2,3
		Repair		1.0				2,3
13	WHEELS							
1311	Wheel Assembly Hub and Drum Assembly	Replace			1.0			2,3
					1.0			2,3
	Wheel Assembly	Inspect	0.1					
		Service		0.3				2,3
		Replace			1.0			3,7,9
		Repair			1.0			3,7,9
1313	Tires	Inspect	0.1					
			0.3					
		Replace		1.0				3,7,9
		Repair		1.0				3,7,9
14	STEERING							
1401	Mechanical Steering Gear Assembly							
	Steering Wheel	Inspect	0.1		0.5			3,4,6
		Replace						2,3
	Tie Rods and System Adjustment	Inspect		0.1				3,7
		Adjust			2.0			3,7,9
		Replace			3.0			3,7,9
		Repair			0.5			3,7,9

MAINTENANCE ALLOCATION CHART - CONTINUED

(1) Group number	(2) Component/Assembly	(3) Maintenance function	(4) Maintenance category					(5) Tools and eqpt	(6) Remarks
			C	O	F	H	D		
14	STEERING - CONTINUED								
1401	Mechanical Steering Gear Assembly - Continued Steering Gear Assembly	Replace			1.0			2,3	
		Repair			1.0			2,3	
	Link, Drag	Inspect		0.1				2,3	
		Replace			0.6			3,7,9	
		Repair			1.0			2,3	
1410	Hydraulic Pump Pump, Rear Steering	Test			0.5			7,12	
		Replace			2.0			3,7,10, 12	
		Repair			2.0			3,7,10, 12	
1411	Hoses, Lines, Fittings	Inspect	0.1						
		Replace		0.5				2,3	
		Repair		0.5				2,3	
1412	Hydraulic Cylinder Cylinder, Steering	Inspect	0.1						
		Replace			1.0			3,7,10	
		Repair			1.0			3,7,10	
1414	Steering System Valves Valve, Steering	Adjust			0.5			3,7	
		Replace			2.0			3,5,7,10	
		Repair			3.0			3,5,7,10	
15	FRAME, TOWING ATTACHMENTS AND DRAWBARS								
1501	Frame Assembly	Inspect		0.2				3	
		Replace			3.0			2,3,9	
	Roll Over Protective Structure	Inspect	0.1						
		Replace				2.0		1,5,7,9	
		Repair				1.0		3,5,7,9	
1502	Counterweights	Replace		1.5				2,3	
1503	Pintles and Towing Attachments Pintle	Inspect		0.2				3	
		Replace		2.0				2,3	
18	BODY, CAB, AND HOOD								
1801	Body, Cab and Hood Assemblies Body Covers and Panels	Inspect		0.1				3	
		Replace		0.1				1,2,3	
	Cockpit	Inspect		0.1				3	
		Replace			16.0			1,2,3	
		Repair			4.0			3,4,5,7, 9,11	

MAINTENANCE ALLOCATION CHART - CONTINUED

(1) Group number	(2) Component/Assembly	(3) Maintenance function	(4) Maintenance category					(5) Tools and eqpt	(6) Remarks
			C	O	F	H	D		
18	BODY, CAB, AND HOOD – CONTINUED								
1801	Body, Cab and Hood Assemblies – Continued Frame Console	Inspect Replace Repair		0.1 1.0 1.0				1,2,3 3,4,5,7, 9,11	
1802	Fenders	Replace		0.5				1,2,3	
1805	Floors, Subfloors, and Related Components Floors	Replace		1.0				1,2,3	
1806	Seals	Inspect Adjust Replace Repair	0.1 0.1	0.5 0.5				1,2,3 1,2,3	
1808	Stowage Racks, Boxes Tool Box	Replace		0.5				2,3	
22	BODY ACCESSORY ITEMS								
2210	Data Plates	Replace		0.5				2,3	
24	HYDRAULIC AND FUEL SYSTEMS								
2401	Pump	Inspect Replace Repair			0.5 2.0 2.0			3,7 3,7,10, 12 3,7,10, 12	
2402	Manifold and Control Valves Pump, Engine Driven	Test Replace Repair			0.5 2.0 2.0			7,12 3,7,10, 12 3,7,10, 12	
	Valves, 2 and 3 Spool	Replace Repair			1.5 1.5			7,10,12 7,10,12	
	Valve, Replenishing	Replace Repair			1.0 1.0			7,10,12 7,10,12	
2403	Hydraulic and Manual Controls Control, Levers and Linkage	Inspect Adjust Replace Repair	0.1	0.2 0.5 0.5				1,2,3 1,2,3	

MAINTENANCE ALLOCATION CHART - CONTINUED

(1) Group number	(2) Component/Assembly	(3) Maintenance function	(4) Maintenance category					(5) Tools and eqpt	(6) Remarks
			C	O	F	H	D		
24	HYDRAULIC AND FUEL SYSTEMS - CONTINUED								
2404	Tilt Cylinders								
	Cylinder, Hydraulic Tilt (MHE-200 w/o ROPS, MHE-222 w/o ROPS)	Inspect Replace	0.1	1.5				3,5,7, 10,12	
	MHE-200 w/ROPS, MHE-222 w/ROPS)	Repair			1.5			3,5,7, 10,12	
	Cylinder Assembly, Tilt (MHE-202 w/o ROPS, MHE-202 w/ROPS)	Inspect Replace	0.1		1.5			3,5,7, 10,12	
		Repair			1.5			3,5,7, 10,12	
2405	Mast Column								
	Forks, Lifting	Inspect Adjust Replace	0.1	0.1 0.5				1,2,3 1,2,3	
	Boom Assembly	Replace			2.0			3,4,5,7	
	Carriage Assembly	Inspect Replace Repair		0.1 0.4 1.5				2,3 1,2,3 3,5,8,1	
	Cylinder, Hydraulic Lift	Inspect Replace Repair	0.1		1.5 1.5			3,5,8,1 3,5,8,1	
2406	Strainers, Filters, Lines and Fittings								
	Hoses, Lines and Fittings	Inspect Replace Repair	0.1	0.5 0.5				1,2,3 1,2,3	
2407	Hydraulic Cylinders								
	Cylinder, Hydraulic Oscillation, Side Shift and Extension	Inspect Replace Repair	0.1		1.0 1.5			3,5,8,1 3,5,8,1	
	Cylinder Assembly, Slave (MHE-200 w/o ROPS, MHE-222 w/o ROPS, MHE-200 w/ROPS, MHE-222 w/ROPS)	Inspect Replace Repair	0.1	1.0	1.5			3,5,7,1 3,5,7,1	
	Cylinder Assembly, Slave (MHE-202 w/o ROPS, MHE-202 w/ROPS)	Inspect Replace Repair	0.1		1.0 1.5			3,5,7,1 3,5,7,1	
2408	Liquid Tanks Or Reservoirs								
	Tank, Hydraulic	Inspect Service Replace Repair	0.1	0.2 2.0 2.0				2,3 3,5,7 3,5,7	
	Filter, Hydraulic	Inspect Service Replace		0.1 0.5 0.5				1,2,3 1,2,3 1,2,3	

Section III. TOOL AND TEST EQUIPMENT REQUIREMENTS

(1) Tool or test equipment ref code	(2) Maintenance category	(3) Nomenclature	(4) National stock number	(5) Tool number
1	0	Shop Equip. Auto Maint: Org Maint. Common No. 2 SC 4910-95-CL-A72	4910-00-754-0650	SC4910-95CLA72
2	0	Shop Equip. Auto Maint: Org Maint. Common No. 1 SC 4910-95-CL-A74	4910-00-754-0654	SC4910-95CLA74
3	0	Tool Kit, General Mech- anics: Auto SC 5180-90-CL-N26	5180-00-177-7033	SC5180-90-CL-N26
4	F	Shop Equip. Welding: Field Maint SC 3470-95-C1 -A08	3470-00-357-7268	SC3470-95CLA08
5	F	Shop Equip. Machine Shop: Field Maint Basic SC 3470-95-CL-A02	3470-00-754-0708	SC3470-95CLA02
6	F	Test Set, Diesel Injector	4910-00-317-8265	5910359
7	F	Shop Equip. Auto Maint: Field Maint, Basic SC 4910-95-CL-A31	4910-00-754-0705	SC4910-95CLA31
8	F	Shop Equip. Fuel and Elec. Sys. Engine: Field Maint. Basic SC 4910-95-CL-A01	4910-00-754-0714	SC4910-95CLA01
9	F	Tool Kit, Light Machine Repair SC 5180-90-CL-N26	5180-00-596-1540	SC5180-90CL-N27
10	F	Tool Kit, Master Mechanics SC 5180-90-CL-N05	5180-00-699-5273	SC5180-90-CL-N05
11	F	Tool Kit, Body and Fender Repair SC 5180-90-CL-N34	5180-00-754-0643	SC5180-90CLN34
12	F	Gauge, Hydraulic pressure 0 - 3000 PSI		H0278M
13		Regulating Kit, Charging P/N 8427780 (19205)	4933-00-856-5593	

Section IV. REMARKS

(1) Reference code	(2) Remarks
	Not Applicable

APPENDIX E
REPAIR PARTS AND SPECIAL TOOLS LIST

There are non authorized.

APPENDIX F

EXPENDABLE SUPPLIES AND MATERIALS LIST

Section I. INTRODUCTION

F-1. Scope

This appendix lists expendable supplies and materials you will need to operate and maintain the rough terrain forklift truck. These items are authorized to you by CTA 50-970, Expendable Items (Except Medical, Class V, Repair Parts, and Heraldic Items).

F-2. Explanation of Columns

a. *Column 1—Item number.* This number is assigned to the entry in the listing and is referenced in the narrative instructions to identify the material (e.g., "Use drycleaning solvent item 1, App F").

b. *Column 2—Level.* This column identifies the lowest level of maintenance that requires the listed item.

- C—Operator/Crew
- O—Organizational Maintenance

c. *Column 3—National Stock Number.* This is the National stock number assigned to the item, use it to request or requisition the item.

d. *Column 4—Description* Indicates the Federal item name and, if required, a description to identify the item. The last line for each item indicates the part number followed by the Federal Supply Code for Manufacturer (FSCM) in parentheses, if applicable.

e. *Column 5— Unit of Measure (U/M).* Indicates the measure used in performing the actual maintenance function. This measure is expressed by a two-character alphabetical abbreviation (e.g., ea, in, pr). If the unit of measure differs from the unit of issue, requestion the lowest unit of issue that will satisfy your requirements.

Section II. EXPENDABLE SUPPLIES AND MATERIALS LIST

(1) Item Number	(2) Level	(3) National Stock Number	(4) Description	(5) U/M
1	C	6850-00-110-4498	Solvent, drycleaning, type II (SD-2) Fed Spec P-D-680	1 pt
2		6850-00-274-5421		5 gal
3		6850-00-281-1985		6 gal
4		6850-00-664-5685		24 qt
5		6850-00-285-8011		55 gal
6		6850-00-637-6135		bulk
7	C	9150-00-186-6668	Engine oil, OE/HDO-10	5 gal
8		9150-00-191-2772	Engine oil, OE/HDO-10	55 gal
9	C	9150-00-402-2372	Engine oil (Arctic)	5 gal
10	C	9150-00-402-4478	Engine oil (Arctic)	1 qt
11		9150-00-491-7197	Engine oil (Arctic)	55 gal
12		9150-00-186-6668	Gear oil	5 gal
13		9150-00-191-2772	Gear oil	55 gal
14	C	9150-00-065-0029	Grease, auto and artillery	2.25 oz
15		9150-00-190-0900	Grease, auto and artillery (8143 g)	4 oz
16		9150-00-190-0905	Grease, auto and artillery (8134 g)	5 lb can
17		9150-00-190-0907	Grease, auto and artillery	35 lb

INDEX

	Paragraph	Page		Paragraph	Page
A					
Administrative storage	1-3	1-1	Lubrication information	3-1	3-1
Air cleaner assembly	4-21	4-11	Lubrication system	4-11	4-5
Assembly after movement	4-4	4-1	Operation	2-1	2-1
B					
Battery	3-8	3-10	Operator and crew preventive maintenance checks and ser- vices (PMCS)	3-3	3-6
Battery and generator indicator	4-45	4-31	Organizational preventive main- tenance checks and services (PMCS)	4-7	4-2
Battery holddown cover	4-34	4-23	Steering system	4-64	4-42
Brake accumulator	4-62	4-40	Transmission	4-53	4-35
Brake pressure switch	4-39	4-27	Troubleshooting, operator and crew	3-5	3-8
C					
Contamination indicator	4-76	4-50	Troubleshooting, organizational	4-9	4-4
Controls and instrument, operator and crew	2-2	2-1	Generator indicator	4-45	4-31
Controls and instrument, organiza- tional	4-43	4-31	H		
Coolant hoses and fittings, oper- ator and crew	3-10	3-11	Horn and lights	4-41	4-28
Coolant hoses and fittings, organ- izational	4-26	4-17	Horn pushbutton	4-48	4-31
Counterweight and pintle	4-70	4-47	Hourmeter, engine	4-44	4-31
Crankcase breather	4-13	4-7	Hydraulic control levers	4-50	4-32
D					
Description	1-6	1-1	Hydraulic hoses	4-77	4-51
Destruction of Army materiel to prevent enemy use	1-4	1-1	I		
Detailed lubrication information	3-2	3-1	Inspecting new equipment	4-1	4-1
Differences among models	1-8	1-2	L		
Differential lockout control	4-51	4-33	Lift cylinder, hydraulic	4-75	4-50
Dismantling for movement	4-3	4-1	Lights	3-13	3-11
Dragline	4-67	4-42	Light switch	4-49	4-32
Drive belts	4-28	4-18	Lights and horn	4-41	4-28
E					
Emergency brake cable and lever	4-60	4-38	Limitations, organizational, troubleshooting	4-10	4-4
Engine air cleaner inspection	3-6	3-10	M		
Engine air cleaner	4-20	4-9	Maintenance forms and records	1-2	1-1
Engine generator	4-33	4-21	Muffler and exhaust pipe	4-17	4-8
Engine oil filler pipe and ca p	4-15	4-7	Muffler inspection	3-12	3-11
Ether primer	3-7	3-10	N		
Exhaust manifold inspection	3-11	3-11	Neutral start switch	4-38	4-25
Exhaust manifold and flange	4-17	4-8	New equipm ent inepection	4-1	4-1
Exhaust pipe inspection	3-12	3-11	O		
Exhaust pipe and muffler	4-17	4-8	Oil fier pipe and cap	4-15	4-7
F					
Fan belt tension control	4-31	4-20	Oil level dipstick	4-14	4-7
Fan blade	4-29	4-20	Oil filter	4-12	4-5
Vanguard	4-27	4-17	Operation of the forklift truck	2-4	2-4
Fan pulley inspection	4-30	4-20	Operation:		
Floodlight	4-42	4-30	In extreme cold	2-6	2-12
Foot controls	4-52	4-34	At high altitudes	2-12	2-13
Fork carriage	4-73	4-48	In extreme heat	2-8	2-12
Fuel filters	4-22	4-12	In dusty or sandy area	2-9	2-13
Fuel pump	4-19	4-9	In salt water area	2-10	2-13
Fuel tank	3-9	3-11	In snow	2-13	2-13
G					
General			Under rainy or humid condi- tions	2-11	2-13
Auxiliary equipment operation	2-6	2-12	Organizational preventive main- tenance checks and services table	4-8	4-2
Brake	4-58	4-38	Oscillator cylinder, hydraulic	4-71	4-48
Controls and instruments	4-43	4-31	P		
Cooling system	4-23	4-14	Panel lights	4-47	4-31
Electrical system	4-32	4-21	Pintle hook	4-70	4-47
Exhaust system	4-16	4-9	Preparation for movement	4-3	4-1
Fuel system	4-18	4-9	Preventive maintenance checks and services operator/crew	3-4	3-6
			Preventive maintenance checks and services organizational	4-8	4-2
			Propeller shaft	4-57	4-37
			Propeller shaft yoke flange	4-57	4-37
			Pulley and hub	4-30	4-20

	Paragraph	Page
R		
Receptacle slave connector	4-35	4-23
Repair parts	4-6	4-2
Reporting equipment improvement recommendations (EAR)	1-5	1-1
Roll over protective structure (RAPS)	4-68	4-43
S		
Scope	1-1	1-1
Seat	4-69	4-45
Servicing equipment	4-2	4-1
Service brakes	4-69	4-38
Side shift roller chain, cylinder, and forks	4-74	4-49
Slack adjusters and lines	4-61	4-39
Slave connector, receptacle	4-36	4-23
Starter pressure switch and mag- netic switch	4-40	4-27
Starter	4-37	4-24
Starter and horn pushbutton switched	4-48	4-31

	Paragraph	Page
Starting	2-3	2-3
Starting aid	2-7	2-12
Steering cylinder, hydraulic	4-66	4-42
flopping	2-5	2-11
T		
Tabulated data	1-7	1-1
Thermostat housing and thermostat	4-24	4-15
Tie rods and tie rod ends	4-65	4-42
Tilt cylinder	4-72	4-48
Tools and equipment	4-5	4-2
Toggle switches	4-46	4-31
Transmission external filter	4-54	4-35
Transmission linkage	4-56	4-37
Transmission oil level check plug	4-55	4-36
Troubleshooting	4-9	4-4
V		
Voltage regulator	4-36	4-24
W		
Water pump	4-25	4-15
Water pump and pulley	4-25	4-15
Wheel flanges, wheels, and tires	4-63	4-41

By Order of the Secretary of the Army:

Official:

J. C. PENNINGTON
Major General United States Army
The Adjutant General

E. C. MEYER
General, United States Army
Chief of Staff



THEN... JOT DOWN THE DOPE ABOUT IT ON THIS FORM. CAREFULLY TEAR IT OUT. FOLD IT AND DROP IT IN THE MAIL!

SOMETHING WRONG WITH THIS PUBLICATION?

FROM: (PRINT YOUR UNIT'S COMPLETE ADDRESS)

Your complete address.

DATE SENT

23 July 80

PUBLICATION NUMBER
TM 10-3930-242-12

PUBLICATION DATE
Jun 80

PUBLICATION TITLE Op & Org. Maint. Manual, 6000 lb. RT Forklift Truck

BE EXACT PIN-POINT WHERE IT IS

PAGE NO	PARA-GRAPH	FIGURE NO	TABLE NO
---------	------------	-----------	----------

4-25	4-21		
------	------	--	--

IN THIS SPACE TELL WHAT IS WRONG AND WHAT SHOULD BE DONE ABOUT IT:

The manual says to refer to para. 4-8 to remove and install the air cleaner. It should refer to para. 4-8. Correct the reference.

SAMPLE

PRINTED NAME GRADE OR TITLE AND TELEPHONE NUMBER
John Smith, SP-4 790-XXXX

SIGN HERE
John Smith

SAMPLE

FILL IN YOUR
UNIT'S ADDRESS

FOLD BACK

DEPARTMENT OF THE ARMY

TEAM ALO.

FONATED LINE

OFFICIAL BUSINESS

Commander
US Army Tank-Automotive Materiel
Readiness Command
ATTN: DRSTA-MB
Warren, MI 48090

RECOMMENDED CHANGES TO EQUIPMENT TECHNICAL PUBLICATIONS

SOMETHING WRONG WITH THIS PUBLICATION?



THEN... JOT DOWN THE
DOPE ABOUT IT ON THIS
FORM. CAREFULLY TEAR IT
OUT. FOLD IT AND DROP IT
IN THE MAIL!

FROM: (PRINT YOUR UNIT'S COMPLETE ADDRESS)

DATE SENT

PUBLICATION NUMBER
TM 10-3930-242-12

PUBLICATION DATE

PUBLICATION TITLE Op & Org. Maint.
Manual, 6000 lb. RT Forklift Truck

BE EXACT PIN-POINT WHERE IT IS

PAGE
NO

PARA-
GRAPH

FIGURE
NO

TABLE
NO

IN THIS SPACE TELL WHAT IS WRONG
AND WHAT SHOULD BE DONE ABOUT IT:

PRINTED NAME GRADE OR TITLE AND TELEPHONE NUMBER

SIGN HERE

RECOMMENDED CHANGES TO EQUIPMENT TECHNICAL PUBLICATIONS



THEN... JOT DOWN THE DOPE ABOUT IT ON THIS FORM. CAREFULLY TEAR IT OUT. FOLD IT AND DROP IT IN THE MAIL!

SOMETHING WRONG WITH THIS PUBLICATION?

FROM: (PRINT YOUR UNIT'S COMPLETE ADDRESS)

DATE SENT

PUBLICATION NUMBER
TM 10-3930-242-12

PUBLICATION DATE

PUBLICATION TITLE Op & Org. Maint.
Manual, 6000 lb. RT Forklift Truck

BE EXACT... PIN-POINT WHERE IT IS

IN THIS SPACE TELL WHAT IS WRONG AND WHAT SHOULD BE DONE ABOUT IT:

PAGE NO	PARA-GRAPH	FIGURE NO	TABLE NO

PRINTED NAME, GRADE OR TITLE, AND TELEPHONE NUMBER

SIGN HERE

FILL IN YOUR
UNIT'S ADDRESS



FOLD BACK

DEPARTMENT OF THE ARMY

OFFICIAL BUSINESS

Commander
US Army Tank-Automotive Materiel
Readiness Command
ATTN: DRSTA-MB
Warren, MI 48090

TEAR AL

PERFORATED LINE

RECOMMENDED CHANGES TO EQUIPMENT TECHNICAL PUBLICATIONS



THEN... JOT DOWN THE DOPE ABOUT IT ON THIS FORM. CAREFULLY TEAR IT OUT. FOLD IT AND DROP IT IN THE MAIL!

SOMETHING WRONG WITH THIS PUBLICATION?

FROM: (PRINT YOUR UNIT'S COMPLETE ADDRESS)

DATE SENT

PUBLICATION NUMBER
TM 10-3930-242-12

PUBLICATION DATE

PUBLICATION TITLE Op & Org. Maint.
Manual, 6000 lb. RT Forklift Truck

BE EXACT... PIN-POINT WHERE IT IS

PAGE NO	PARA-GRAPH	FIGURE NO	TABLE NO
---------	------------	-----------	----------

IN THIS SPACE TELL WHAT IS WRONG AND WHAT SHOULD BE DONE ABOUT IT:

PRINTED NAME, GRADE OR TITLE, AND TELEPHONE NUMBER

SIGN HERE:

FILL IN YOUR
UNIT'S ADDRESS

FOLD BACK

DEPARTMENT OF THE ARMY

OFFICIAL BUSINESS

Commander
US Army Tank-Automotive Materiel
Readiness Command
ATTN: DRSTA-MB
Warren, MI 48090

TEAR
PERFORATED LINE

PIN: 027713-000